

NOZZLE SCHEDULE			
MARK	QTY	SIZE / RATING	DESCRIPTION
N1	1	2" ANSI 150	INLET
N2	1	2" ANSI 150	OUTLET
N3	2	1/2" NPT CL3000	PRESSURE GAUGE
N4	1	1/2" NPT CL3000	VENT
VESSEL DESIGN CONDITIONS			
CODE: ASME SECTION VIII DIV. 1, 2017 EDITION			
M.A.W.P.: 150 PSI @ 400°F		M.D.M.T.: -20° F @ 150 PSI	
M.A.W.P.: FV PSI @ 400°F			
CORROSION ALLOWANCE: -		HYDROTEST PRESS: 195 PSI	
STAMP: UM		SERVICE: WATER	
PWHT: N/A		RADIOGRAPHY: N/A	
MATERIAL: CS		GASKET: BUNA	

**Notes**

1. Vessel will house 1 double length bag filter

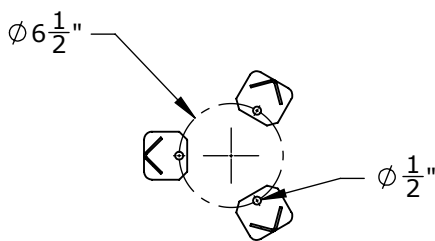
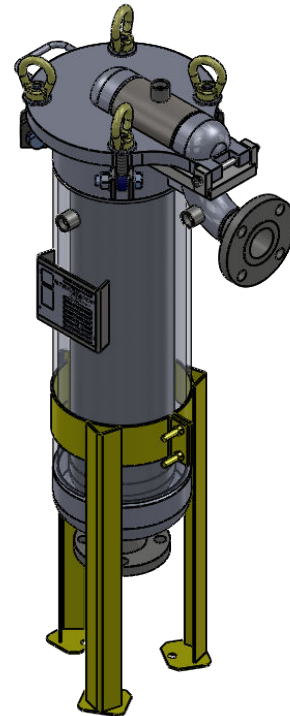
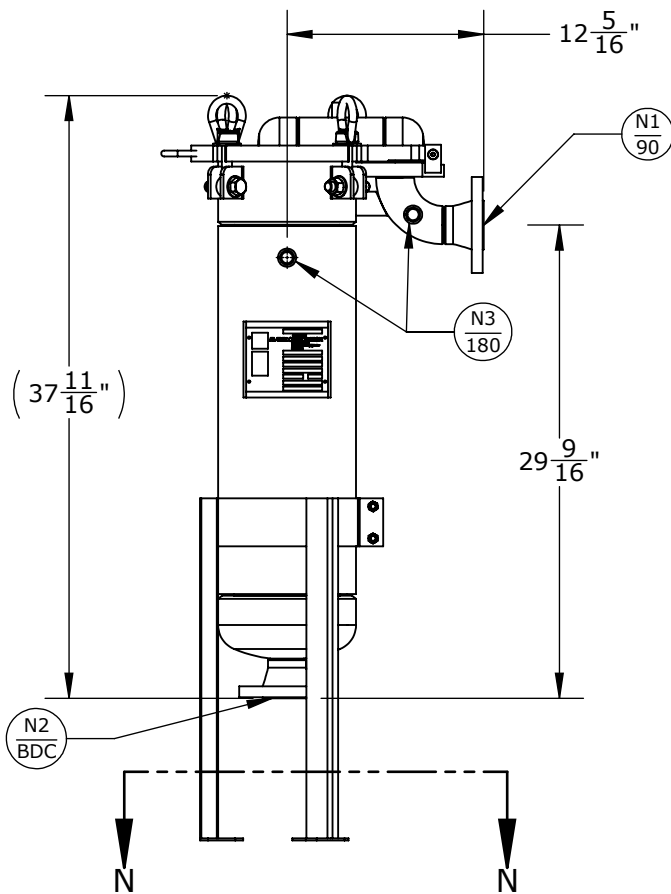

**SECTION N-N**

<p>THIRD ANGLE PROJECTION</p> <p>TOLERANCES-UNLESS OTHERWISE NOTED</p> <p>DECIMAL .X = ±.1" .XX = ±.02" .XXX = ±.005"</p> <p>FRACTIONAL = ±1/8"</p> <p>ANGULAR = ± 1°</p> <p>MAX. MACHINED SURFACE FINISH 125/√</p>	<p><b>FIL-TREK CORPORATION</b></p> <p>55 Stafford Court Cambridge, Ontario N1T 1B3 Canada</p> <p>Phone: (519) 623-7448 Fax: (519) 623-8807 Email: info@fil-trek.com Website: www.fil-trek.com</p>				
	<p>THIS DRAWING IS THE PROPERTY OF 'FIL-TREK CORPORATION' AND MUST NOT BE COPIED OR USED IN ANY WAY DETRIMENTAL TO THE CORPORATION</p> <p>EQUIPMENT: TOP LINE SINGLE BAG FILTER HOUSING</p> <p>MODEL NO: TL112-2F-275</p> <p>CUSTOMER:</p>				
PARENT: NONE	DRAWN: AJ	DATE: 10/05/2019	SERIAL No.	Part No. 002006-00035	REV. No. 0
	CHK'D:	SCALE: NTS			