



# SIGMA PRO

Multi-screen polymeric self-cleaning filter



# MASTERS OF FILTRATION



Any Technology



Anywhere



Any Challenge



Any Water Source



**Your water challenge.**  
**Our filtration solution.**

**Amiad Water Systems is a world leader in water treatment and filtration solutions.** For over 57 years Amiad has devoted its passion and commitment to developing a comprehensive line of water filtration systems for a wide range of industrial applications.

Our solutions are integrated into the core of water filtration systems in the following industries and applications: metal, plastic, energy, chemical, water treatment and salt water disposal.

We develop filters that are able to cope with any water quality, in any geographical location.

We've spent years mastering filtration technology so we can offer a wide range of filters for every industrial need, including screen, disc, microfiber or media technology.



Disc Technology



Screen Technology



Media Technology



Microfiber Technology

We consider every challenge as an opportunity to work side by side with our customers to solve their problems.

We'll go anywhere to ensure our filters perform as expected, 24/7, every day of the year.

When you want a high-performance solution for your water filtration system, consult with Amiad. We focus on doing what we do best.

**Amiad. Masters of Filtration.**

# SIGMAPRO FEATURES



Easy installation and  
low maintenance



Reliable and  
durable



Registered  
patent



Low energy consumption



Large filtration  
area



Powerful suction-  
scanning cleaning



Polymeric filter -  
corrosion free



Scan to watch  
the Sigma Pro animation

# ADI-P: the control is in your hands



## The ADI-P Controller

The ADI-P Controller operates the automated processes that flush your Sigma Pro filters, allowing you to control and monitor them easily and conveniently.

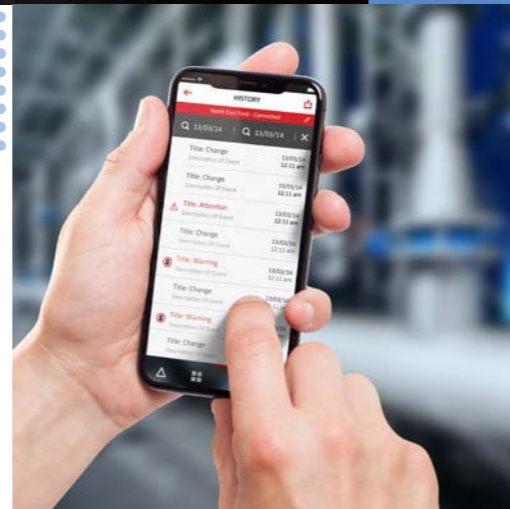

## The ADI-P App

Access your site's filtration performance data directly from the ADI-P app. Here are some of the data that you can access via the ADI-P app:

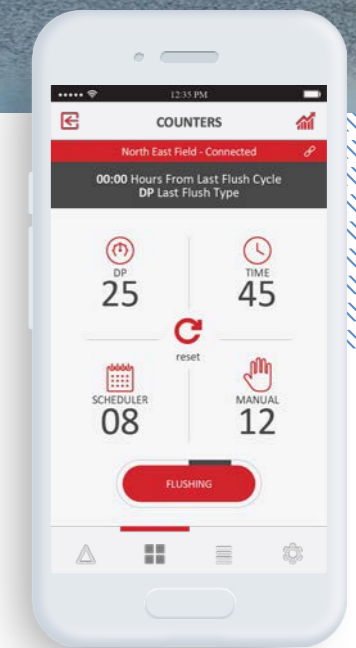

- Flush logs
- Flush frequency
- Current DP
- Current outlet and inlet pressure
- Flush quality - measuring DP on the filter before and after flush cycle
- Malfunctions with descriptions of each event
- Battery status and low battery alerts



Suitable for low pressure (1.5-10 bar)



Single or dual solenoid

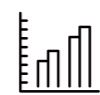

Provides detailed filtration performance data



Communication within **Bluetooth®** technology range



Offline information storage available

# SIGMAPRO Models

## 4" SIGMAPRO

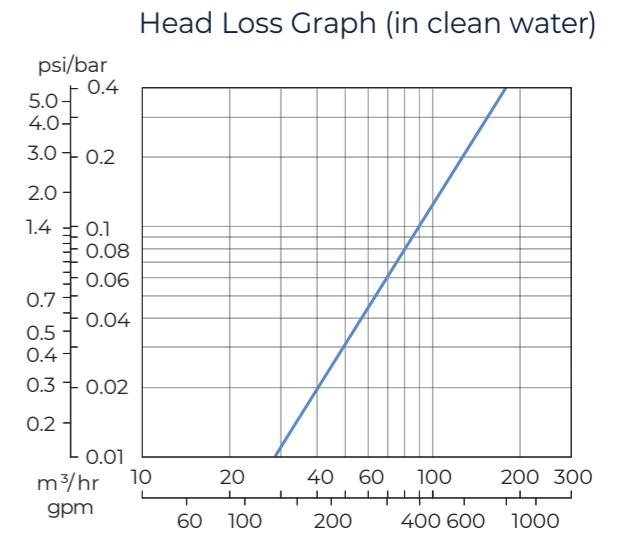
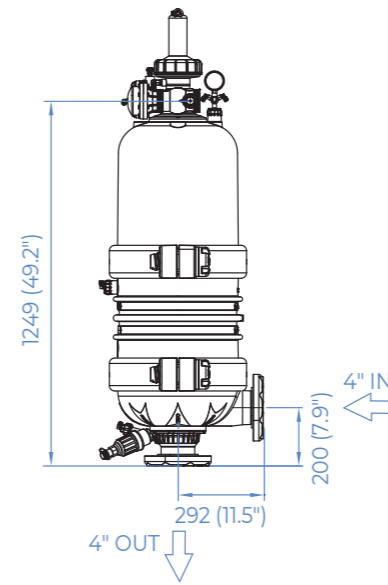
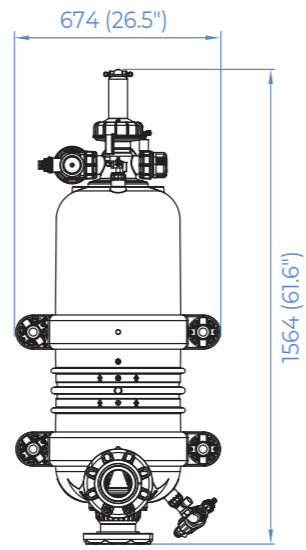

## 6" SIGMAPRO

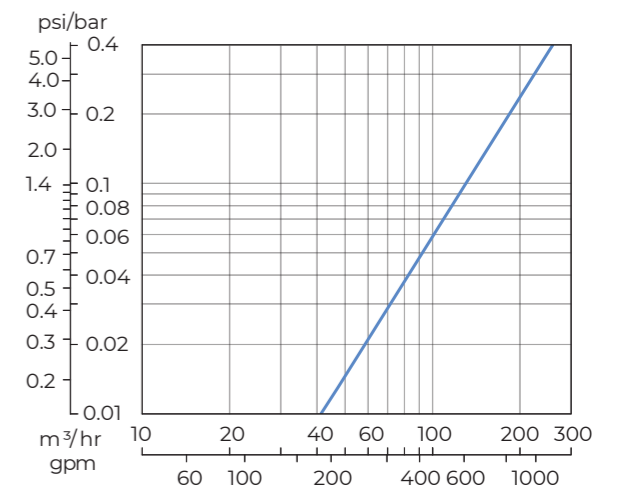
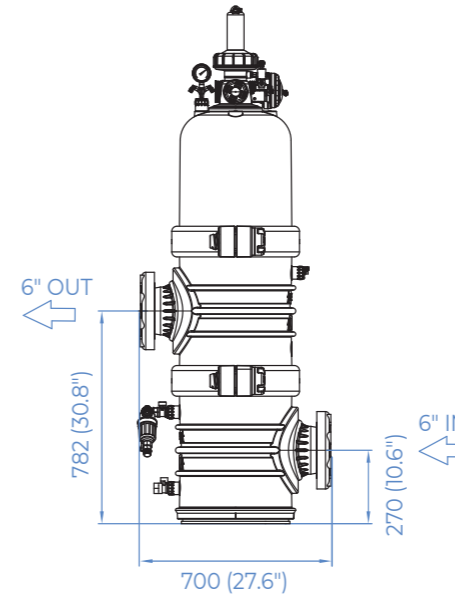
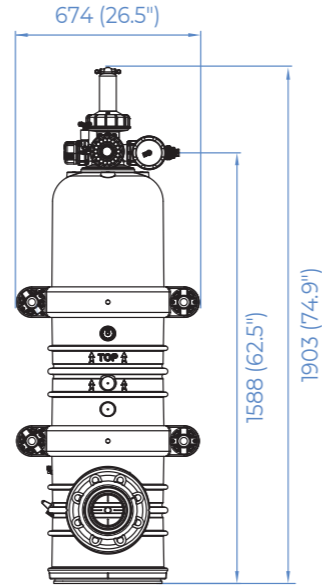

## 8" SIGMAPRO

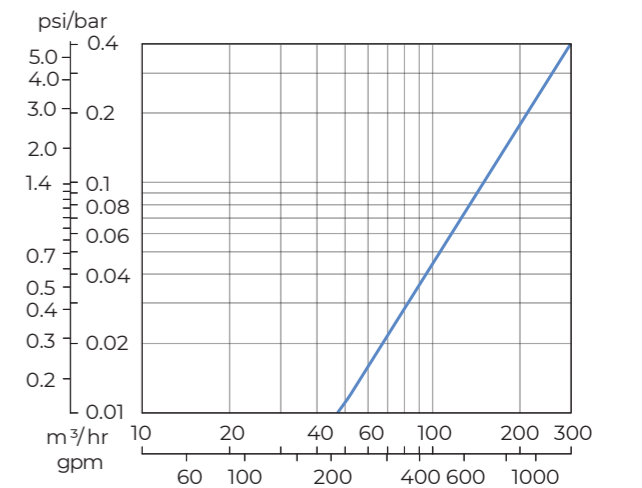
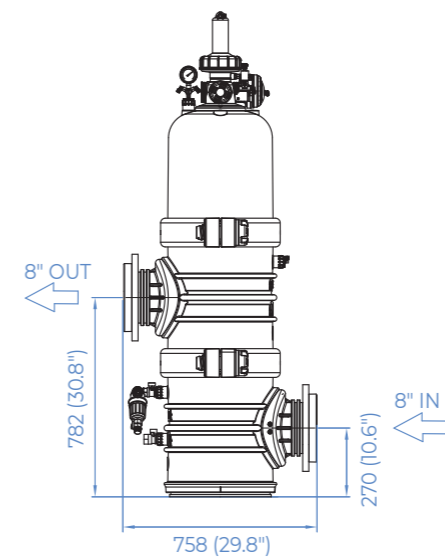
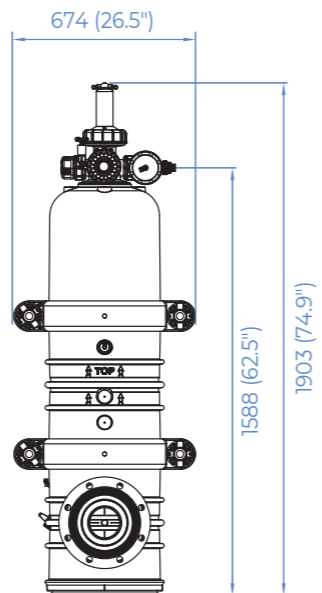

# SIGMAPRO: A Closer Look

## Sigma Pro Parts

1. Flush valve
2. ADI-P controller
3. Hydraulic turbines
4. Fine screens
5. Coarse screens

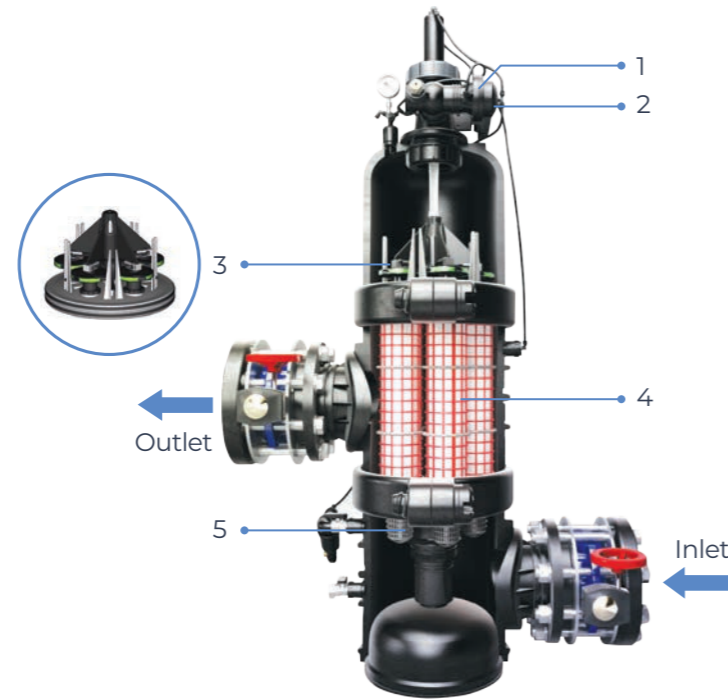

### Various Inlet / Outlet Configurations

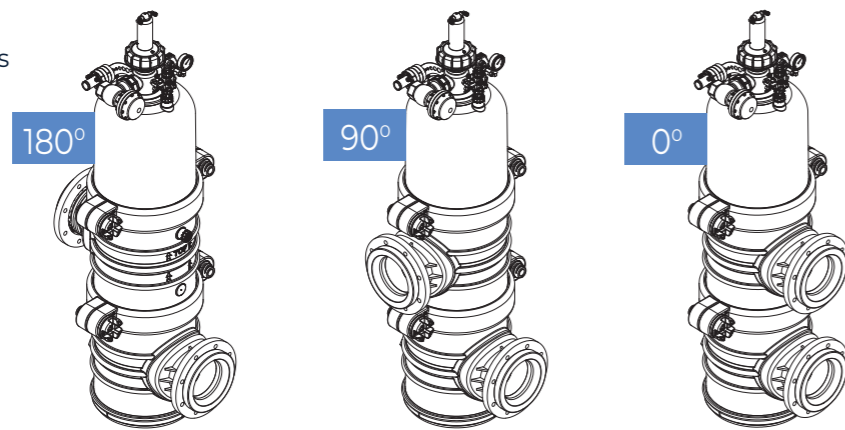

Sigma Pro 8" installation of 4 units with manifold, for flow rates up to 1,120 m<sup>3</sup>/h (4,932 gpm)

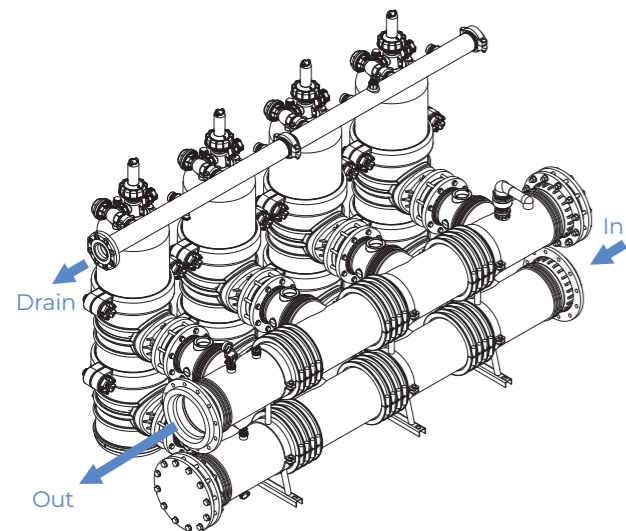

Sigma Pro 6" installation of 2 units with manifold, for flow rates up to 360 m<sup>3</sup>/h (1,584 gpm)

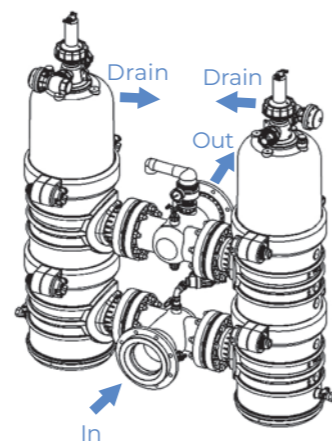

## Technical Specifications

Filter Model	4" Sigma Pro	6" Sigma Pro	8" Sigma Pro
<b>General data</b>			
Max. flow rate* (130µ) in average water quality	120 m <sup>3</sup> /h (528 gpm)	180 m <sup>3</sup> /h (792 gpm)	280 m <sup>3</sup> /h (1,233 gpm)
Min. operating pressure when cleaning	1.5 bar (22 psi)		
Max. operating pressure	10 bar (145 psi)		
Max. operating temperature**	60°C (140°F)		
Filtration area	6,000 cm <sup>2</sup> (930 in <sup>2</sup> )	8,000 cm <sup>2</sup> (1,240 in <sup>2</sup> )	
Inlet/Outlet diameter	4" (100 mm) Flange & Grooved coupling	6" (150 mm) Flange	8" (200 mm) Flange
Weight	Empty: 75 kg (165 lb) Full: 145 kg (320 lb)	Empty: 110 kg (243 lb) Full: 225 kg (496 lb)	Empty: 120 kg (264 lb) Full: 235 kg (518 lb)

\* Maximum flow rates depend on water quality and micron size.

\*\* Maximum operating pressure and temperature are interdependent parameters and are given for general reference only. Please consult your authorized Amiad representative for the application specific parameters.

### Electronic control

Control power supply	4 x AA type 1.5V batteries / External 7-14V DC
Solenoid operation data	9-12V DC latching solenoid
DP switch	Integrated sensors

### Flushing data

Exhaust valve	2" (50 mm)	
Flushing time	10 seconds	
Reject water volume per flush cycle	75 liters (20 gallons)	90 liters (24 gallons)
Min. flow for flushing (at 1.5 bar/22 psi)	34 m <sup>3</sup> /h (150 gpm)	36 m <sup>3</sup> /h (158 gpm)

### Construction materials

Filter housing and lid	PP (Polypropylene) RPA (reinforced polyamide)
Screens	Molded weave wire, stainless steel 316L
Cleaning mechanism	PBT (polybutylene)
Exhaust valve	Polymeric
Seals	EPDM
Control command tubing	PE (polyethylene)

### Standard Filtration Degrees

micron	500	300	200	130	100	80
mm	0.5	0.3	0.2	0.13	0.1	0.08



## Headquarters

**Amiad Water Systems Ltd.**

Web: [www.amiad.com](http://www.amiad.com)

E-mail: [info@amiad.com](mailto:info@amiad.com)

## The Americas

### USA

**Amiad USA Inc.**

Web: [us.amiad.com](http://us.amiad.com) | E-mail: [infousa@amiad.com](mailto:infousa@amiad.com)

### Mexico

**Amiad México SA DE CV,**

Web: [es.amiad.com](http://es.amiad.com) | E-mail: [infomexico@amiad.com](mailto:infomexico@amiad.com)

## Asia

### India

**Amiad Filtration India Pvt Limited**

Web: [amiad.com](http://amiad.com) | E-mail: [info-india@amiad.com](mailto:info-india@amiad.com)

### China

**Amiad China (Yixing Taixing Environtec Co., Ltd.)**

Web: [amiad.com.cn](http://amiad.com.cn) | E-mail: [infochina@amiad.com](mailto:infochina@amiad.com)

### South-East Asia

**Filtration & Control Systems Pte. Ltd.**

Web: [amiad.com](http://amiad.com) | E-mail: [info-singapore@amiad.com](mailto:info-singapore@amiad.com)

## Australia

**Amiad Australia Pty Ltd.**

Web: [au.amiad.com](http://au.amiad.com) | E-mail: [sales@amiad.com](mailto:sales@amiad.com)

## Europe

**Amiad Water Systems Europe SAS**

Web: [amiad.com](http://amiad.com) | E-mail: [industry-europe@amiad.com](mailto:industry-europe@amiad.com)

### German branch office

Web: [de.amiad.com](http://de.amiad.com) | E-mail: [industry-de@amiad.com](mailto:industry-de@amiad.com)

### United Kingdom

**Amiad Water Systems UK Limited**

Web: [amiad.com](http://amiad.com) | E-mail: [info-uk@amiad.com](mailto:info-uk@amiad.com)



 **amiad** INDUSTRY

# MASTERS OF FILTRATION

[www.amiad.com](http://www.amiad.com)

910101-001257/10.2021

Copyright © 2019 Amiad Water Systems Ltd. All rights reserved. The contents of this catalogue including without limitation all information and materials, images, illustrations, designs, icons, photographs, graphical presentations, designs, literary works, data, drawings, slogans, phrases, names, trademarks, titles and any other such materials that appear in this catalogue (collectively, the "Contents") are the sole property of Amiad Water Systems Ltd. ("Amiad"). Amiad has sole and exclusive right, title and interest in the Contents, including any intellectual property rights, whether registered or not, and all know-how contained or embodied therein. You may not reproduce, publish, transmit, distribute, display, modify, create derivative works from, sell or participate in any sale of, or exploit in any way, in whole or in part, any of the Contents or the catalogue. Any use of the catalogue or the Contents, other than for personal use, requires the advanced written permission of Amiad.

The Bluetooth® word mark and logos are registered trademarks owned by the Bluetooth SIG, Inc. and any use of such marks by Amiad Water Systems is under license. Other trademarks and trade names are those of their respective owners.

For more details about our patents go to: [www.amiad.com](http://www.amiad.com)