



ELP SERIES

Bag Filter Housing
Industrial Design
Universal



CONTENTS

- A. Shut Down and Cover Removal
- B. Media Replacement Components
- C. Cover Replacement and Start-Up
- D. Warranty
- E. Spare Parts List

ELP SERIES

Installation and Operation Manual

WARNING:

Please read installation, operation manual, and media installation/replacement instructions prior to operating your ELP Fil-Trek vessel.

Improper use of this model can result in personal injury and property damage.

FIL-TREK CORPORATION

ONTARIO	ALBERTA
70 Fleming Drive	7476 49 th Avenue
Cambridge, ON	Red Deer, AB
N1T 2B1	T4P 1M2
PH: (519) 623-7448	PH: (403) 346-6476
FX: (519) 623-8807	FX: (403) 346-5152

EMAIL: info@fil-trek.com
WEBSITE: www.fil-trek.com

A) SHUT DOWN AND COVER REMOVAL

SWING BOLT CLOSURE

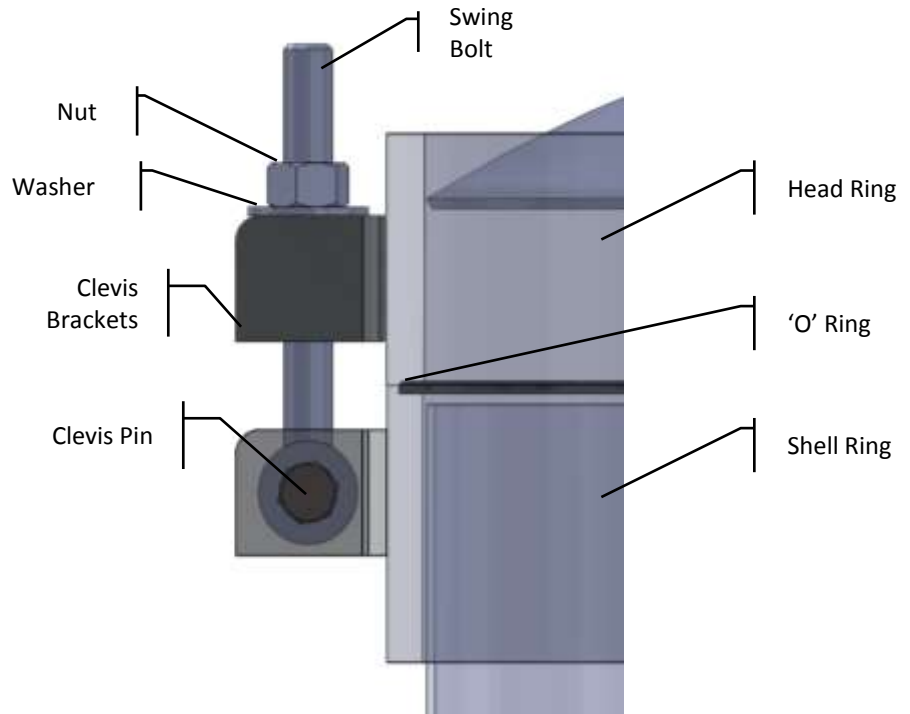

Operator Warning: Do not attempt to open the filter housing while the inlet/outlet valves are open, or while the filter housing contains pressure.

1. Inlet and/or pressure inlet valve must always be closed first.
2. Shut off outlet and/or discharge side valve(s).
3. Any pressure, which may be in the filter housing after the inlet and outlet valves have been closed, should be vented before attempting to open the filter housing. Care should be taken to keep face and hands protected and clear of filter vessel while venting the filter housing.
4. Drain the filter housing by opening the side and bottom drain valves. The dirty drain is located on the side of the ELP Series filter housing and the clean drain is located on the bottom of the vessel.

CAUTION: Do not, at any time remove or loosen the swing bolts before draining. Failure to drain the vessel can result in pressurized fluid being trapped in the vessel. Fluid may spray out when the swing bolts are loosened causing personal injury or damage to equipment.

FIL-TREK CORPORATION

ONTARIO

70 Fleming Drive
Cambridge, ON
N1T 2B1

PH: (519) 623-7448
FX: (519) 623-8807

ALBERTA

7476 49th Avenue
Red Deer, AB
T4P 1M2

PH: (403) 346-6476
FX: (403) 346-5152

5. Open the air vent to relieve the housing pressure.
6. Loosen the cover nuts (eye or hex) in an alternate diagonal pattern.
7. A head lift with a hand wheel is standard on all vessels that are greater than 12" diameter or have a cover weighing more than 30lbs. Make sure to raise the cover high enough to clear the cartridge compression springs and guide pin.

B) MEDIA REPLACEMENT COMPONENTS

ELP SERIES

Bag Filter Housing
Industrial Design
Universal

Fil-Trek ELP model housings will accept most size two and size one filter bags. These filter bags are supported by perforated filter baskets. For maximum filtration efficiency, Fil-Trek recommends that bags should be replaced @ 15-20 PSI D dirty unless otherwise specified

1. After the cover is removed, lift the used filter bag by grasping the loop on the bag and lifting the bag upwards.
2. Once the filter bag is removed it is then discarded.
3. Then remove the support basket out of the vessel to clean and inspect the basket for any damage.
4. Clean and inspect the filter housing interior and all components. The o-ring groove and o-ring must be inspected for damage.
5. Install the support basket into the ELP housing.
6. Install the new Fil-Trek filter bag.
7. Make sure to spread out the filter bag inside the support basket.

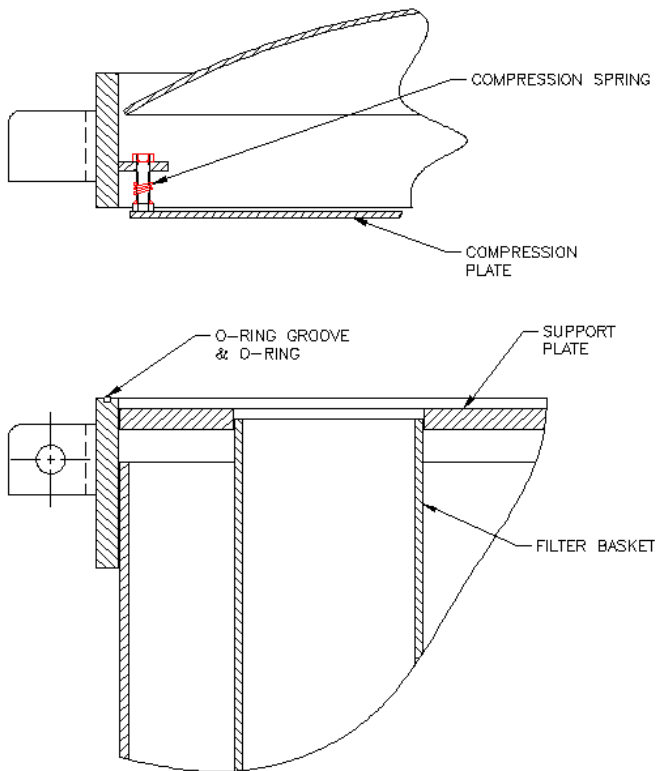

THE WARRANTY IS VOID IF ANY OF THE SPARE PARTS ARE NOT SUPPLIED BY FIL-TREK CORPORATION OR ONE OF ITS DIVISIONS.

FIL-TREK CORPORATION

ONTARIO	ALBERTA
70 Fleming Drive	7476 49 th Avenue
Cambridge, ON	Red Deer, AB
N1T 2B1	T4P 1M2
PH: (519) 623-7448	PH: (403) 346-6476
FX: (519) 623-8807	FX: (403) 346-5152

EMAIL: info@fil-trek.com
WEBSITE: www.fil-trek.com

ELP SERIES

Bag Filter Housing
Industrial Design
Universal

C) COVER REPLACEMENT AND START-UP

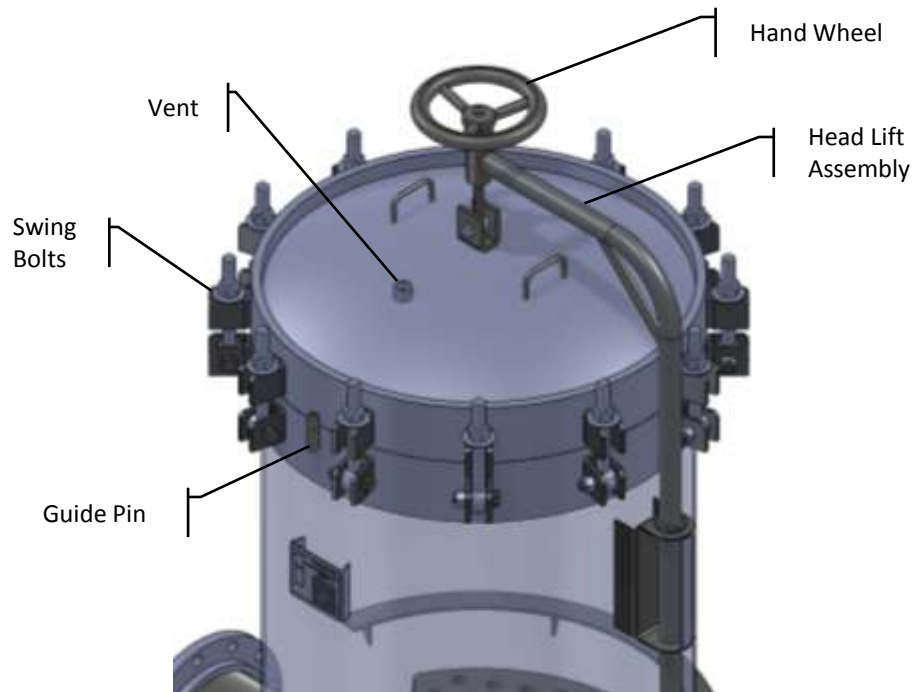

1. Clean and inspect the gasket seating surface. Re-lubricate the gasket heavily with petroleum jelly.
2. Swing bolts and nuts should be cleaned, inspected and lubricated.
3. Position the cover over the filter body and align the clevis bracket notches with the swing bolts. If your ELP Series vessel has a domed top head there will be a guide pin, which will assist with aligning the cover into place. After the cover is properly aligned, turning the hand wheel, in a counterclockwise motion, will lower the cover.
4. After the cover is lowered into place, position the swing bolts to the cover and install the nuts (hex or eye).
5. Tighten the nuts by following the torque procedure.
6. Close the drain valve and open the vent valve or plug.
7. Open the inlet valve and allow the vessel to fill slowly.
8. When air is expelled from the vessel and liquid begins to bleed from the vent, close the vent valve.
9. Open the outlet valve(s).

FIL-TREK CORPORATION

ONTARIO

70 Fleming Drive
Cambridge, ON
N1T 2B1

PH: (519) 623-7448
FX: (519) 623-8807

ALBERTA

7476 49th Avenue
Red Deer, AB
T4P 1M2

PH: (403) 346-6476
FX: (403) 346-5152

EMAIL: info@fil-trek.com

WEBSITE: www.fil-trek.com

TORQUE PROCEDURE

The torque procedure is as follows:

1. Bolts must be all be snug tight before starting.
2. Apply the starting torque, shown below working in a star pattern.

BOLT SIZE	STARTING TORQUE
1/2"	20 ft-lbs.
5/8"	30 ft-lbs.
3/4"	40 ft-lbs.
1"	50 ft-lbs.
1 1/8"	75 ft-lbs.

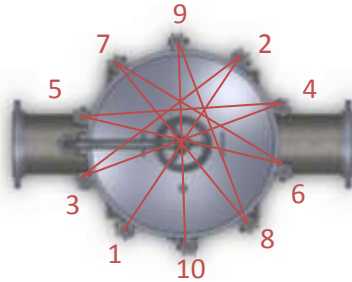

3. Apply an additional 20ft-lbs of torque working in the same star pattern
4. Bring the vessel up to working pressure.
5. If the vessel begins to leak from the seal, relieve the pressure by 25% from where the pressure vessel began to leak. After the pressure has been dropped add additional 15ft-lb increments in the same star pattern until the unit is sealed. Do not exceed the specified maximum value of torque shown below and do not over torque the vessel to the point of bending the vessel's washers.

BOLT SIZE	MAXIMUM TORQUE
1/2"	100 ft-lbs.
5/8"	150 ft-lbs.
3/4"	200 ft-lbs.
1"	250 ft-lbs.
1 1/8"	300 ft-lbs.

TROUBLESHOOTING

If cover is still leaking after following the above torque procedure:

1. Remove the cover and inspect the O-Ring.
2. Make sure O-Ring is clean, not twisted, pinched or damaged and well lubricated.
3. Make sure mating faces are clean and undamaged.
4. If problem persists, contact Fil-Trek.

FIL-TREK CORPORATION

ONTARIO	ALBERTA
70 Fleming Drive	7476 49 th Avenue
Cambridge, ON	Red Deer, AB
N1T 2B1	T4P 1M2
PH: (519) 623-7448	PH: (403) 346-6476
FX: (519) 623-8807	FX: (403) 346-5152

EMAIL: info@fil-trek.com
WEBSITE: www.fil-trek.com

D) WARRANTY

Seller warrants that the items sold hereunder shall be free from defects in material or workmanship for a period of *12 MONTHS AFTER STARTUP* or *18 MONTHS AFTER THE DATE OF SHIPMENT* from Fil-trek Corporation or one of its divisions, whichever comes first. This warranty comprises the sole and entire warranty pertaining to items provided hereunder. Seller makes no other warranty, guarantee, or representation of any kind whatsoever. All other warranties, including but not limited to, merchantability and fitness for purpose, whether express, implied, or arising by operation of law, trade usage, or course of dealing, are hereby disclaimed.

Notwithstanding the foregoing, there are no warranties whatsoever on items built or acquired wholly or partially, to buyer's designs or specifications.

Limitation of Remedy: Seller's liability arising from or in any way connected with the items sold or this contract shall be limited exclusively to repair or replacement of the items sole or refund of the purchase price by buyer, at seller's sole option. In no event shall seller be liable for any incidental, consequential, or special damages of any kind or nature whatsoever, including but not limited to lost profits arising from or in any way connected with this agreement or items sold hereunder, whether alleged to arise from breach of contract, express or implied warranty, or in tort, including without limitation, negligence, failure to warn or strict liability.

THE WARRANTY IS VOID IF ANY OF THE SPARE PARTS ARE NOT SUPPLIED BY FIL-TREK CORPORATION OR ONE OF ITS DIVISIONS.

FIL-TREK CORPORATION

ONTARIO

70 Fleming Drive
Cambridge, ON
N1T 2B1

PH: (519) 623-7448

FX: (519) 623-8807

ALBERTA

7476 49th Avenue
Red Deer. AB
T4P 1M2

PH: (403) 346-6476

FX: (403) 346-5152

EMAIL: info@fil-trek.com

WEBSITE: www.fil-trek.com

E) SPARE PARTS LIST

ELP SERIES

Bag Filter Housing
Industrial Design
Universal

SERIAL NUMBER _____

MODEL NUMBER _____

QTY _____

CUSTOMER _____

YEAR BUILT _____

PART NUMBER	DESCRIPTION	QTY REQUIRED PER UNIT	QTY TO ORDER

Note: ELP Series housings accept universal size 1 and 2 bag filters.
Please visit our website for more information.

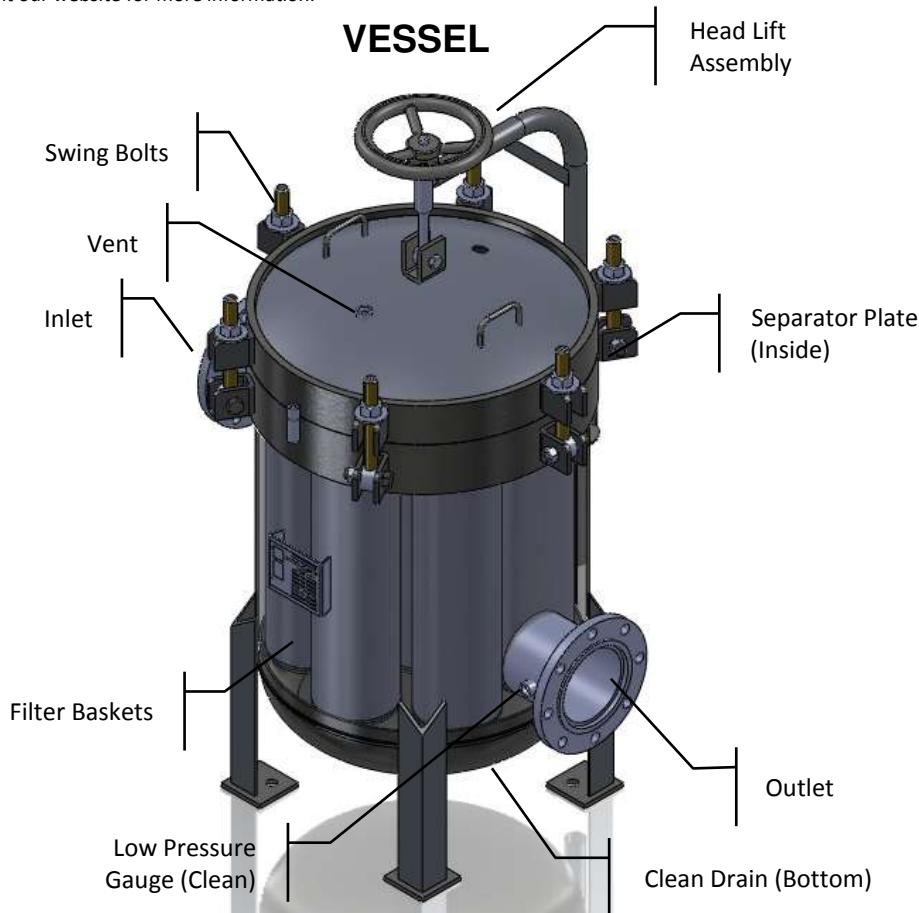

FIL-TREK CORPORATION

ONTARIO	ALBERTA
70 Fleming Drive	7476 49 th Avenue
Cambridge, ON	Red Deer, AB
N1T 2B1	T4P 1M2
PH: (519) 623-7448	PH: (403) 346-6476
FX: (519) 623-8807	FX: (403) 346-5152

EMAIL: info@fil-trek.com
WEBSITE: www.fil-trek.com

FOR SPARE PARTS INQUIRIES OR FOR A DETAILED DRAWING OF YOUR HOUSING, PLEASE CONTACT FIL-TREK DIRECTLY.