

NOZZLE SCHEDULE			
MARK	QTY	SIZE / RATING	DESCRIPTION
N1	1	4" 150# RFWN	INLET
N2	1	4" 150# RFWN	OUTLET
N3	2	1/2" 3000# NPT	PRESSURE GAUGE
N4	1	1/2" 3000# NPT	VENT
N5			
N6	1	2" 3000# NPT	DIRTY DRAIN

VESSEL DESIGN CONDITIONS	
CODE: ASME SECTION VIII DIV. 1, 2015 EDITION	
M.A.W.P.: 150 PSI @ 250°F	M.D.M.T.: -20° F @ 150 PSI
M.A.E.P.: 15 PSI @ 250°F	
CORROSION ALLOWANCE: NONE	HYDROTEST PRESS: 195 PSI
STAMP: U	SERVICE: NON LETHAL
PWHT: N/A	RADIOGRAPHY: N/A
MATERIAL: SS316	GASKET: BUNA

NOTES:

1. VESSEL DRY WEIGHT: **380.38** LBS.
2. SHIPPING WEIGHT: **450** LBS.
3. FLOODED WEIGHT: **800** LBS.
4. VESSEL VOLUME: **7.5** CU. FT.
5. VESSEL WILL HOUSE (QTY=41) 40" LG, DOE CARTRIDGE.

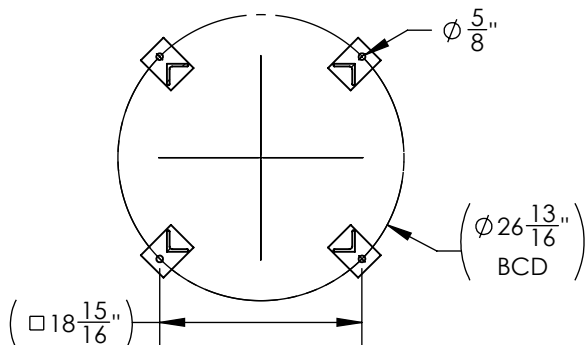
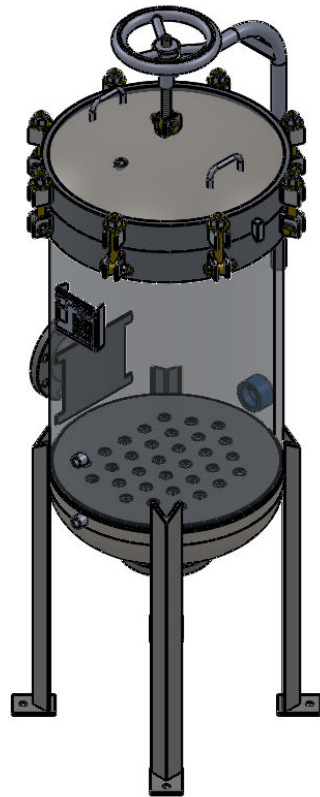
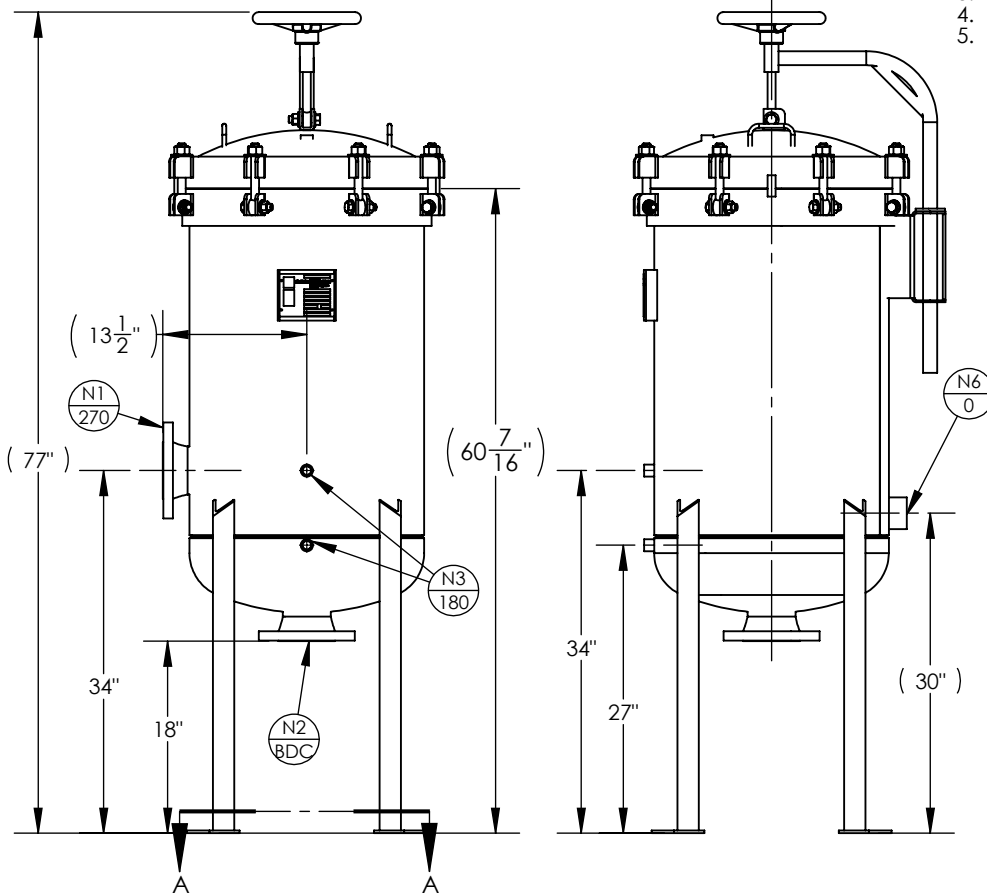

<p>THIRD ANGLE PROJECTION TOLERANCES-UNLESS OTHERWISE NOTED</p> <p>DECIMAL .X = ±.1" .XX = ±.02" .XXX = ±.005"</p> <p>FRACTIONAL = ±1/8"</p> <p>ANGULAR = ± 1°</p> <p>MAX. MACHINED SURFACE FINISH 125/√</p>	<p>FIL-TREK CORPORATION 55 Stafford Court Cambridge, Ontario N1T 1B3 Canada</p> <p>Phone: (519) 623-7448 Fax: (519) 623-8807 Email: info@fil-trek.com Website: www.fil-trek.com</p>				
	<p>THIS DRAWING IS THE PROPERTY OF 'FIL-TREK CORPORATION' AND MUST NOT BE COPIED OR USED IN ANY WAY DETRIMENTAL TO THE CORPORATION</p> <p>EQUIPMENT: CARTRIDGE (GL SERIES)</p> <p>MODEL NO: S6HPI22-041-3-4F-150</p> <p>CUSTOMER:</p>				
PARENT:	DRAWN: VD CHK'D:	DATE: 2/14/2017 SCALE: NTS	SERIAL No.	Part No. 001019-00008	REV. No. 0