

NOZZLE SCHEDULE			
MARK	QTY	SIZE / RATING	DESCRIPTION
N1	1	6" 150# RFSO	INLET
N2	1	6" 150# RFSO	OUTLET
N3	2	1/2" 3000# NPT	PRESSURE GAUGE
N4	1	1/2" 3000# NPT	VENT
N5	1	2" 150# NPT	CLEAN DRAIN
N6	1	2" 150# NPT	DIRTY DRAIN

VESSEL DESIGN CONDITIONS	
CODE: BEST COMMERCIAL PRACTICE	
M.A.W.P.:	150 PSI @ 400°F
M.A.E.P.:	FV PSI @ 400°F
M.D.M.T.:	-20° F @ 150 PSI
HYDROTEST PRESS:	195 PSI
MATERIAL:	SS 304

NOTES:

1. VESSEL DRY WEIGHT: **345.18 LBS.**
2. SHIPPING WEIGHT: **550 LBS.**
3. FLOODED WEIGHT: **900 LBS.**
4. VESSEL VOLUME: **8.1 CU. FT.**
5. VESSEL WILL HOUSE (QTY=32) 2.5"OD x 40" LG CARTRIDGE.

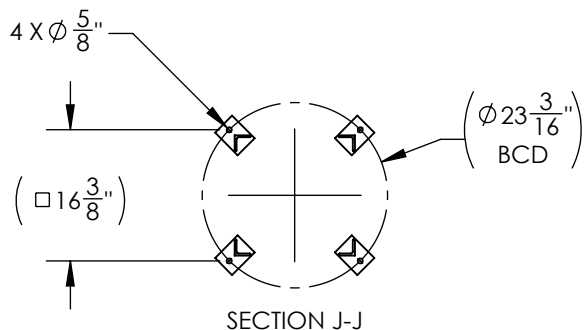
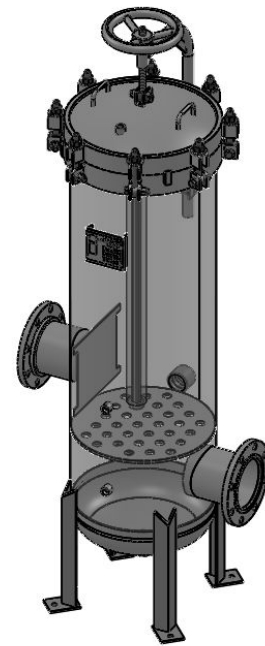
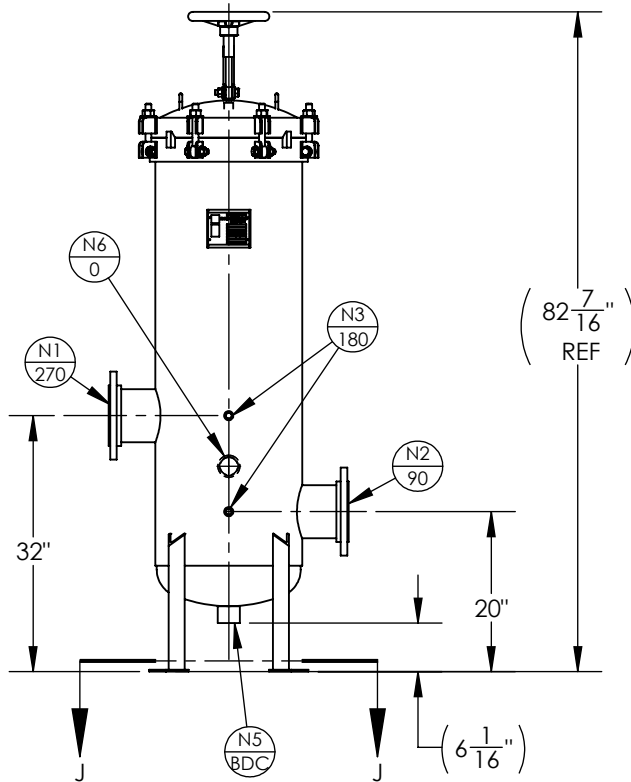

APPROVED WITH MARK-UPS <input type="checkbox"/>		APPROVED <input type="checkbox"/>	
 THIRD ANGLE PROJECTION	 FIL-TREK CORPORATION		
	55 Stafford Court Cambridge, Ontario N1T 1B3 Canada		Phone: (519) 623-7448 Fax: (519) 623-8807 Email: info@fil-trek.com Website: www.fil-trek.com
<small>THIS DRAWING IS THE PROPERTY OF 'FIL-TREK CORPORATION' AND MUST NOT BE COPIED OR USED IN ANY WAY DETRIMENTAL TO THE CORPORATION</small>			
EQUIPMENT:		EGL SERIES (CARTRIDGE FILTER VESSEL)	
MODEL NO:		S4EGL18-032-4-6F-150	
CUSTOMER:			
PARENT:	DRAWN: JN	DATE: 26/06/2017	SERIAL No. Part No. 001022-00077
CHK'D:	SCALE: NTS		REV. No. 0