

SECTION K-K

NOZZLE SCHEDULE			
MARK	QTY	SIZE / RATING	DESCRIPTION
N1	1	6" 150# RFSO	INLET
N2	1	6" 150# RFSO	OUTLET
N3	2	1/2" 3000# NPT	PRESSURE GAUGE
N4	1	1/2" 3000# NPT	VENT
N5	1	1" 3000# NPT	CLEAN DRAIN
N6	1	1" 3000# NPT	DIRTY DRAIN

VESSEL DESIGN CONDITIONS	
CODE:	ASME SECTION VIII DIV. 1, 2015 EDITION
M.A.W.P.:	150 PSI @ 400°F M.D.M.T.: -20° F @ 150 PSI
M.A.W.P.:	FV PSI @ 400°F
CORROSION ALLOWANCE:	NONE HYDROTEST PRESS: 195 PSI
STAMP:	U SERVICE: NON LETHAL
PWHT:	N/A RADIOGRAPHY: N/A
MATERIAL:	SS316 GASKET: BUNA-N

- NOTES:
1. VESSEL DRY WEIGHT: **371 LBS.**
 2. SHIPPING WEIGHT: **500 LBS.**
 3. FLOODED WEIGHT: **770 LBS.**
 4. VESSEL VOLUME: **6.45 CU. FT.**
 5. VESSEL WILL HOUSE (QTY=25) 2.5"OD x 40" DOE CARTRIDGES.

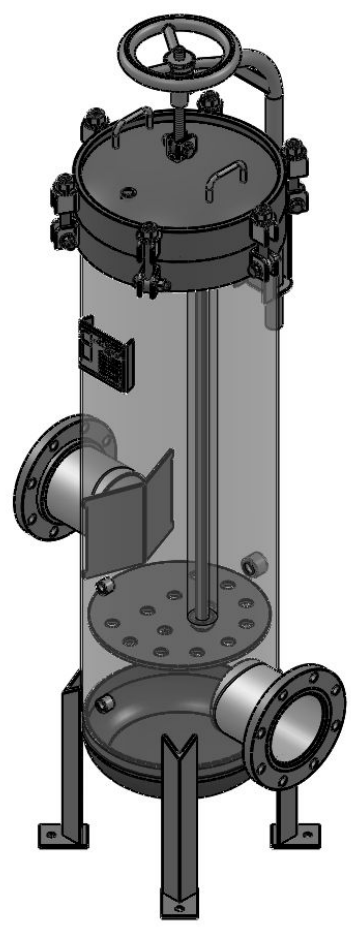

APPROVED WITH MARK-UPS <input type="checkbox"/>		APPROVED <input type="checkbox"/>	
<p>THIRD ANGLE PROJECTION</p>		<p>FIL-TREK CORPORATION</p>	
<p>TOLERANCES-UNLESS OTHERWISE NOTED</p> <p>DECIMAL .X = ±.1" .XX = ±.02" .XXX = ±.005"</p> <p>FRACTIONAL = ±1/8"</p> <p>ANGULAR = ± 1°</p> <p>MAX. MACHINED SURFACE FINISH 125/√</p>		<p>55 Stafford Court Cambridge, Ontario N1T 1B3 Canada</p> <p>Phone: (519) 623-7448 Fax: (519) 623-8807 Email: info@fil-trek.com Website: www.fil-trek.com</p>	
THIS DRAWING IS THE PROPERTY OF 'FIL-TREK CORPORATION' AND MUST NOT BE COPIED OR USED IN ANY WAY DETRIMENTAL TO THE CORPORATION			
EQUIPMENT:		GL SERIES (CARTRIDGE FILTER VESSEL)	
MODEL NO:		S6GL16-025-4-6F-150	
CUSTOMER:			
PARENT: NEW	DRAWN: JN	DATE: 13/06/2017	SERIAL No. Part No. 001001-00338
CHK'D:	SCALE: NTS		REV. No. 0