

NOZZLE SCHEDULE			
MARK	QTY	SIZE / RATING	DESCRIPTION
N1	1	8" 150# RFSO	INLET
N2	1	8" 150# RFSO	OUTLET
N3	2	1/2" 3000# NPT	PRESSURE GAUGE
N4	1	1/2" 3000# NPT	VENT
N5	1	2" 3000# NPT	CLEAN DRAIN
N6	1	2" 3000# NPT	DIRTY DRAIN

VESSEL DESIGN CONDITIONS	
CODE:	ASME SECTION VIII DIV. 1, 2017 EDITION
M.A.W.P.:	150 PSI @ 400°F
M.D.M.T.:	-50° F @ 150 PSI
M.A.W.P.:	FV PSI @ 400°F
CORROSION ALLOWANCE:	N/A
HYDROTEST PRESS:	210 PSI
STAMP:	U
SERVICE:	LIQUID NON LETHAL
PWHT:	N/A
RADIOGRAPHY:	NONE
MATERIAL:	SS316
GASKET:	BUNA

NOTES:

1. VESSEL WILL HOUSE (QTY=81) 2.5"OD x 40" LG DOE CARTRIDGES.
2. DRY WEIGHT: 921.91 LBS.
3. FLODDED WEIGHT: 2140
4. SHIPPING WEIGHT: 1100 LBS.
5. VESSEL VOLUME: 20 FT<sup>3</sup>

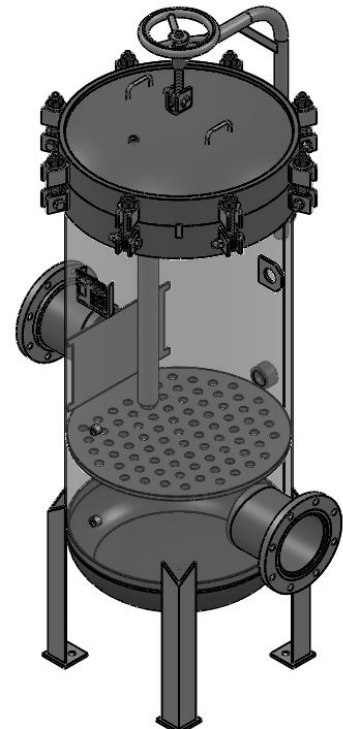

APPROVED WITH MARK-UPS  APPROVED

<p>THIRD ANGLE PROJECTION</p>	<p><b>FIL-TREK CORPORATION</b></p>	
	<p>55 Stafford Court Cambridge, Ontario N1T 1B3 Canada</p>	<p>Phone: (519) 623-7448 Fax: (519) 623-8807 Email: info@fil-trek.com Website: www.fil-trek.com</p>
<p>THIS DRAWING IS THE PROPERTY OF 'FIL-TREK CORPORATION' AND MUST NOT BE COPIED OR USED IN ANY WAY DETRIMENTAL TO THE CORPORATION</p>		
<p>EQUIPMENT: GL SERIES (CARTRIDGE FILTER VESSEL)</p>		
<p>MODEL NO: S6GL28-081-4-8F-150</p>		
<p>CUSTOMER:</p>		
<p>PARENT: NEW DESIGN</p>	<p>DRAWN: JN CHK'D: JP</p>	<p>DATE: 02/01/2018 SCALE: NTS</p>
<p>SERIAL No.</p>	<p>Part No. 001001-00336</p>	<p>REV. No. 0</p>