

NOZZLE SCHEDULE			
MARK	QTY	SIZE / RATING	DESCRIPTION
N1	1	4" 150# RFSO	INLET
N2	1	4" 150# RFSO	OUTLET
N3	2	1/2" 3000# NPT	PRESSURE GAUGE
N4	1	1/2" 3000# NPT	VENT
N5	1	1" 3000# NPT	CLEAN DRAIN
N6	1	1" 3000# NPT	DIRTY DRAIN

VESSEL DESIGN CONDITIONS			
CODE: ASME SECTION VIII DIV. 1, 2015 EDITION			
M.A.W.P.: 150 PSI @ 400°F		M.D.M.T.: -20° F @ 150 PSI	
M.A.W.P.: FV PSI @ 400°F			
CORROSION ALLOWANCE: NONE		HYDROTEST PRESS: 195 PSI	
STAMP: UM		SERVICE: NON LETHAL	
PWHT: NONE		RADIOGRAPHY: NONE	
MATERIAL: SS316		GASKET: BUNA	

NOTES:

1. VESSEL DRY WEIGHT: **301 LBS.**
2. SHIPPING WEIGHT: **400 LBS.**
3. FLOODED WEIGHT: **630 LBS.**
4. VESSEL VOLUME: **5 CU. FT.**
5. VESSEL WILL HOUSE (QTY=19) 2.5"OD x 40" LG DOE CARTRIDGES

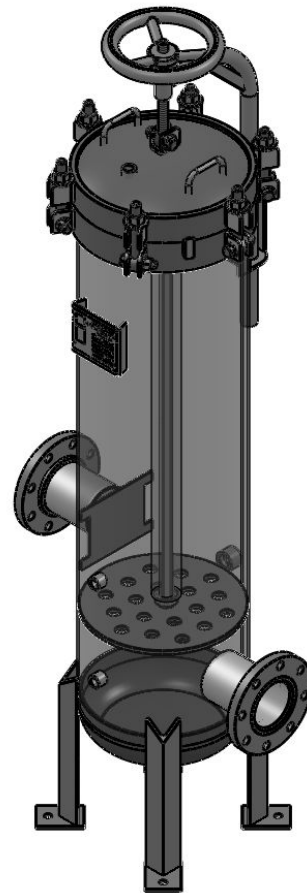

APPROVED WITH MARK-UPS APPROVED

THIRD ANGLE PROJECTION
 TOLERANCES-UNLESS OTHERWISE NOTED
 DECIMAL .X = ±.1" .XX = ±.02" .XXX = ±.005"
 FRACTIONAL = ±1/8"
 ANGULAR = ± 1°
 MAX. MACHINED SURFACE FINISH 125/√

FIL-TREK CORPORATION
 55 Stafford Court
 Cambridge, Ontario
 N1T 1B3
 Canada
 Phone: (519) 623-7448
 Fax: (519) 623-8807
 Email: info@fil-trek.com
 Website: www.fil-trek.com

THIS DRAWING IS THE PROPERTY OF 'FIL-TREK CORPORATION' AND MUST NOT BE COPIED OR USED IN ANY WAY DETRIMENTAL TO THE CORPORATION

EQUIPMENT: GL SERIES (CARTRIDGE FILTER VESSEL)
 MODEL NO: S6GL14-019-4-4F-150
 CUSTOMER:

PARENT: NEW DESIGN
 DRAWN: JN
 DATE: 12/06/2017
 SERIAL No.
 Part No. 001001-00355
 REV. No. 0