

NOZZLE SCHEDULE			
MARK	QTY	SIZE / RATING	DESCRIPTION
N1	1	8" 150# RFSO	INLET
N2	1	8" 150# RFSO	OUTLET
N3	2	1/2" 3000# NPT	PRESSURE GAUGE
N4	1	1/2" 3000# NPT	VENT
N5	1	2" 3000# NPT	CLEAN DRAIN
N6	1	2" 3000# NPT	DIRTY DRAIN
VESSEL DESIGN CONDITIONS			
CODE: ASME SECTION VIII DIV. 1, 2015 EDITION			
M.A.W.P.: 150 PSI @ 400°F		M.D.M.T.: -20° F @ 150 PSI	
M.A.E.P.: FV PSI @ 400°F			
CORROSION ALLOWANCE: NONE		HYDROTEST PRESS: 195 PSI	
STAMP: U		SERVICE: NON LETHAL	
PWHT: N/A		RADIOGRAPHY: N/A	
MATERIAL: SS304		GASKET: BUNA-N	

NOTES:

- VESSEL WILL HOUSE (QTY=68) 2.5"OD x 40" LG DOECARTRIDGE.
- VESSEL DRY WEIGHT: **868.68** LBS.
- SHIPPING WEIGHT: 1000 LBS.
- FLOODED WEIGHT: **2200** LBS.
- VESSEL VOLUME: **21.5** FT³

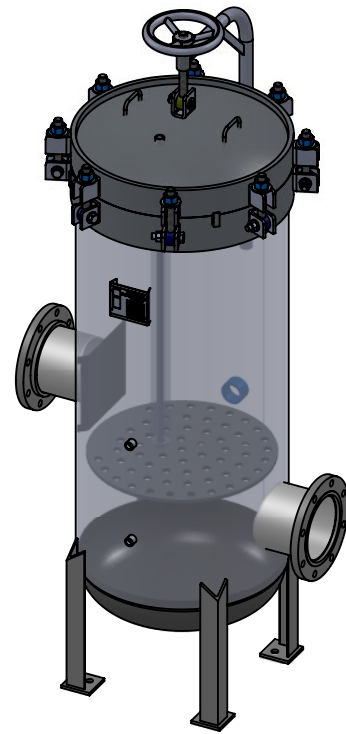

APPROVED WITH MARK-UPS APPROVED

THIRD ANGLE PROJECTION
 TOLERANCES-UNLESS OTHERWISE NOTED
 DECIMAL .X = ±.1" .XX = ±.02" .XXX = ±.005"
 FRACTIONAL = ±1/8"
 ANGULAR = ± 1°
 MAX. MACHINED SURFACE FINISH 125/√

FIL-TREK CORPORATION
 55 Stafford Court
 Cambridge, Ontario
 N1T 1B3
 Canada
 Phone: (519) 623-7448
 Fax: (519) 623-8807
 Email: info@fil-trek.com
 Website: www.fil-trek.com

THIS DRAWING IS THE PROPERTY OF 'FIL-TREK CORPORATION' AND MUST NOT BE COPIED OR USED IN ANY WAY DETRIMENTAL TO THE CORPORATION

EQUIPMENT: CARTRIDGE FILTER VESSEL (GL SERIES)
 MODEL NO: S4GL26-068-4-8F-150
 CUSTOMER:

PARENT: NEW DESIGN	DRAWN: GB	DATE: 29/06/2017	SERIAL No.	Part No. 001001-00370	REV. No. 0
CHK'D:	SCALE: NTS				