

DVF Series

High efficiency media water filtration systems



flow rates

up to 50 m³/h

filtration performance

down to 1 micron*

inlet/outlet diameters

up to 3"

minimum operating pressure

1 bar (14.5 psi)

features:

- All stainless steel vessel material construction. Special alloys upon request
- High performance filtration through a combination of unique design and specially formulated media
- Up to 95% filtration efficiency of process water
- Filtration of up to 4 times more water than conventional media filters, which achieve only 20 micron filtration
- Shorter backwash times compared to conventional media filters
- Cleans contaminated systems and improves performance
- Up to 95% reduction in backwash loss of process water
- Operational inlet pressure of only 1 bar
- High filtration performance during high flow rates
- Applications: intake water, full/side stream, heat exchangers protection, recycling water, pre RO/UV, drinking water, polishing and more

* Media bed construction dependent

How DVF Filters Work

General

The Amiad DVF automatic filter is an extremely simple yet highly effective technology that offers a more effective method of water filtration. The DVF series consists of 4 filters that can handle flow rates from 1.4 m³/h with the smaller DVF300 vessel and up to 50 m³/h with the larger DVF1200 vessel.

The Filtering Process

Untreated water enters via the inlet which is located at the top of the vessel and is passed through the patented DVF vortex generator. This vortex generator has a dual outlet configuration inside the vessel which generates a double vortex. This allows for the solids to be suspended above the filter bed. This allows the water that is being cleaned to flow through the media bed with less resistance, thus providing longer intervals between required backwashing. The filter bed is constructed of different grades of active glass media of which the coarse layer is used at the bottom, followed by additional layers of support media and the special blend top layer. The cleaning process is achieved by backwashing the media.

The Self-Cleaning Process

Backwashing the filter bed is achieved by either a set time or, if backwashing is needed sooner, a pressure differential gauge which senses the Delta P when it reaches the pre-set value, triggering the self-cleaning process. The inlet valve shuts followed by the process outlet valve. The backwash inlet valve then opens followed by the backwash outlet valve (drain). This forces the water being used for backwashing up through the nozzles at the bottom of the vessel, through the filter bed which lifts the solids from the top layer of the media. Once lifted off the bed it is discharged through the backwash outlet (drain) which is located at the top of the vessel. When the backwash is finished at a pre-determined time, the valves shut in reverse and the filtering process is resumed.

The Control System

The Amiad AC controller which is used with the DVF Series allows for the backwash timings to be altered to suit the specific site requirements. It also allows for pumps to be added to the system to aid with process and/or backwash flow. There is also a manual backwash facility which will work in conjunction with the set time and differential pressure settings for the filters.

The self-cleaning cycle is initiated as a result of any of the following:

- Receiving a signal from the pressure differential gauge
- Time interval parameter set at the controller
- Manual start
- Remote access

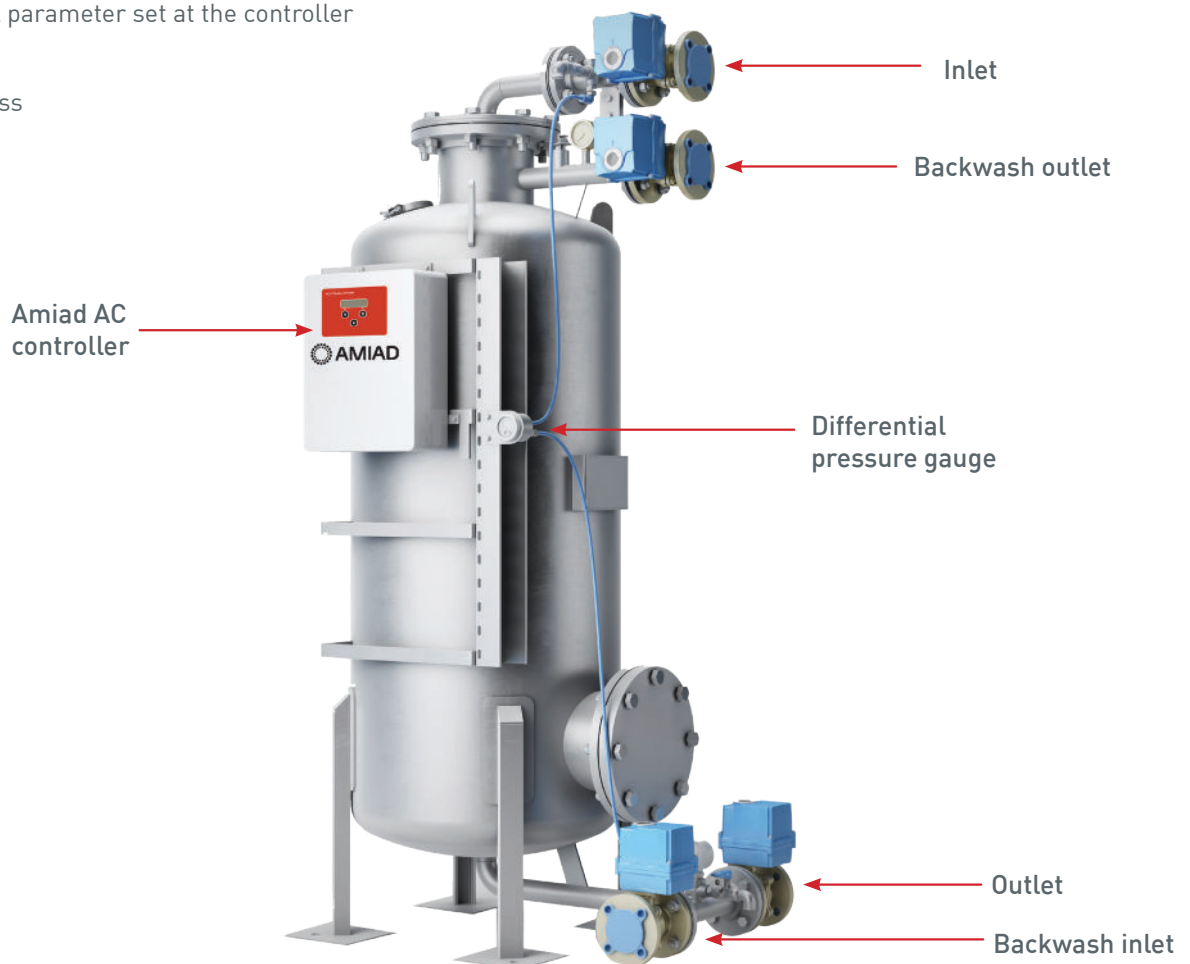

DVF 300/600/900/1200

Technical Specifications

Filter Type	DVF 300	DVF 600	DVF 900	DVF 1200
General Data				
Flow rate	1.4-3 m ³ /h	4-12 m ³ /h	10-28 m ³ /h	20-50 m ³ /h
Flange connection interface*	1" DN 25 ISO PN10 Flanged	1½" DN 40 ISO PN10 Flanged	2" DN 50 ISO PN10 Flanged	3" DN 80 ISO PN10 Flanged
Design pressure maximum	7 bar	7 bar		
Minimum working pressure	1 bar			
Maximum temperature	60°C			
Maximum backwash flow	1.7 m ³ /h	6 m ³ /h	13 m ³ /h	22 m ³ /h
Control panel power supply	110v or 240v/1/50hz			
Filter operational weight, dry (approx.)	375 kg	955 kg	1995 kg	3795 kg

* Different flange types available upon special request

Construction Materials	
Filter vessel	Stainless steel 304L built according to EN13445 pressure code
Nozzles*	Polypropylene for use up to 60°C
Gaskets*	EPDM
Filter media	Multi level graded AFM

* Other construction materials and coatings for corrosive use or for drinking water are available upon request.

DVF 300/600/900/1200

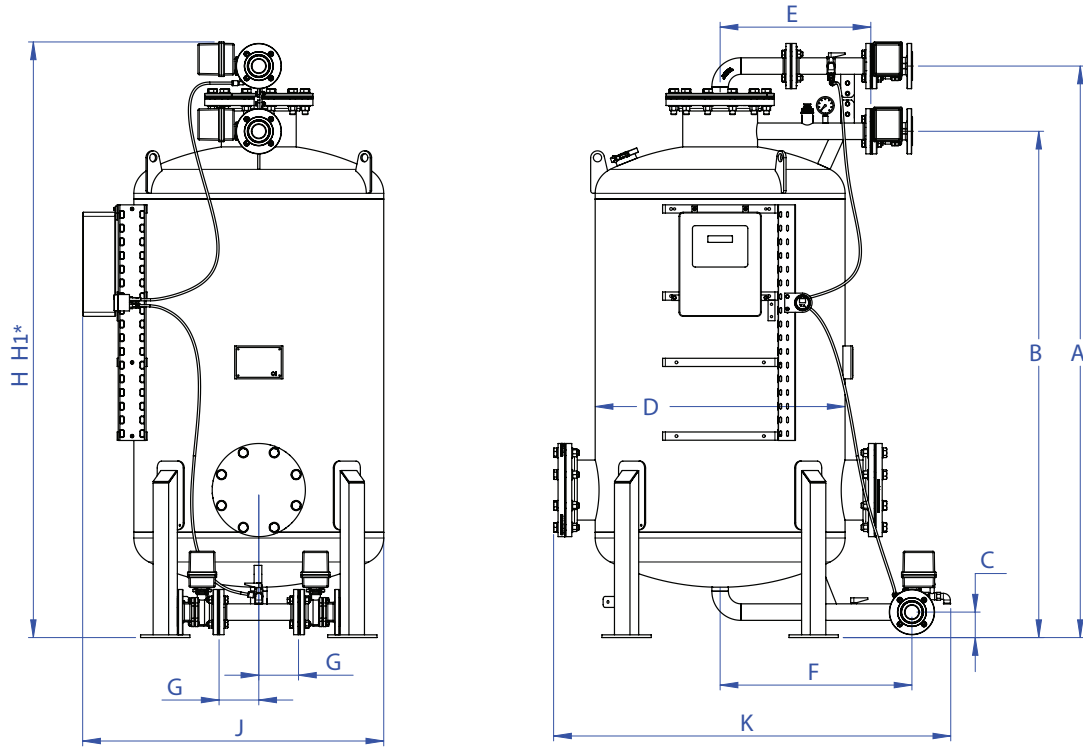

Approximate Dimensions

Model	A	B	C	D	E	F	G	H	H1*	J	K
DVF300	1615 mm	1410 mm	100 mm	323.9 mm	297 mm	297 mm	172 mm	1759 mm	2200 mm	615 mm	654 mm
	[63.58"]	[55.51"]	[3.94"]	[12.75"]	[11.69"]	[11.69"]	[6.77"]	[69.27"]	[86.61"]	[24.20"]	[25.73"]
DVF600	1917 mm	1706 mm	109 mm	612mm	418 mm	560 mm	147 mm	2005 mm	2503 mm	786 mm	1022 mm
	[75.46"]	[67.16"]	[4.29"]	[24.09"]	[16.46"]	[22.06"]	[5.79"]	[78.93"]	[98.54"]	[30.94"]	[40.24"]
DVF900	2086	1848 mm	93 mm	912 mm	550 mm	700 mm	145 mm	2174 mm	2742 mm	1099 mm	1449 mm
	[82.12"]	[72.75"]	[3.66"]	[35.91"]	[21.65"]	[27.56"]	[5.71"]	[85.58"]	[107.95"]	[43.26"]	[57.07"]
DVF1200	2521 mm	2186 mm	150 mm	1210	755 mm	755 mm	146 mm	2621 mm	3370 mm	1410 mm	1667 mm
	[99.26"]	[86.08"]	[5.90"]	[47.64"]	[29.72"]	[29.72"]	[5.75"]	[103.20"]	[132.68"]	[55.49"]	[65.61"]

*H1 - Approx. height required for maintenance
 Dimensions are for reference only. Certified drawings are available upon request.

Headquarters

Amiad Water Systems Ltd.

Web: www.amiad.com | E-mail: info@amiad.com

The Americas



USA

Amiad USA Inc.

Web: www.amiadusa.com | E-mail: infousa@amiad.com

Brazil

Amiad Sistemas de Água Ltda.

E-mail: infobrasil@amiad.com

Mexico

Amiad México SA DE CV,

Web: www.amiad.es | E-mail: infomexico@amiad.com

Irrigation office: E-mail: infomexico-irr@amiad.com

Asia



India

Amiad Filtration India Pvt Limited

Web: www.amiadindia.com | E-mail: info-india@amiad.com

China

Amiad China (Yixing Taixing Environtec Co., Ltd.)

Web: www.amiad.com.cn | E-mail: infochina@amiad.com

South-East Asia

Filtration & Control Systems Pte. Ltd.

E-mail: info-singapore@amiad.com

Australia



Amiad Australia Pty Ltd.

Web: www.amiad.com.au | E-mail: sales@amiad.com

Europe



Amiad Water Systems Europe SAS

E-mail: industry-europe@amiad.com

German branch office

E-mail: industry-de@amiad.com

United Kingdom

Amiad Water Systems UK Limited

E-mail: info-uk@amiad.com

