

D-26

Combination Air Valve for Wastewater



Description

The D-26 Combination Air Valve combines an air & vacuum component and an air release component in a single body. The valve is specifically designed to operate with liquids carrying solid particles such as wastewater and effluents. The combination air valve discharges air (gas) during the filling or charging of the system, admits air into the system during drainage and at water column separation and releases accumulated air (gas) from the system while it is operating under pressure. The valve's unique design enables the separation of the liquid from the sealing mechanism and assures optimum working conditions.

Applications

- Wastewater and water treatment plants.
- Wastewater and effluent water transmission lines.

Operation

The air & vacuum component discharges air at high flow rates during the filling of the system and admits air into the system at high flow rates during its drainage and at water column separation. At any time during system operation, should internal pressure of the system fall below atmospheric pressure, air will enter the system. The smooth discharge of air reduces pressure surges and other destructive phenomena.

The intake of air in response to negative pressure protects the system from destructive vacuum conditions and prevents damage caused by water column separation. Air entry is essential to efficiently drain the system.

The air release component releases entrapped air in pressurized systems.

Without air valves, pockets of accumulated air may cause the following hydraulic disturbances:

- Restriction of effective flow due to a reduction of the flow area. In extreme cases this will cause complete flow stoppage.
- Obstruction of efficient hydraulic transmission due to air flow disturbances.
- Acceleration of cavitation damages.
- Increase in pressure transients and surges.
- Internal corrosion of pipes, fittings and accessories.
- Dangerous high-energy bursts of compressed air.
- Inaccuracies in flow metering.

As the system fills and is pressurized, the combination wastewater air valve functions in the following stages:

1. Air (gas) is discharged by the valve
2. When the liquid level reaches the valve's lower portion, the float is lifted, pushing the sealing mechanism to its sealing position.
3. The entrapped air is confined in a pocket between the liquid

and the sealing mechanism. The air pressure is equal to the system pressure.

4. Increases in system pressure compress the trapped air in the upper section of the conical chamber. The conical shape assures the height of the air gap. This enables separation of the liquid from the sealing mechanism.

5. Entrapped air (gas), accumulating at peaks and along the system, rises to the top of the valve and displaces the liquid in the valve's body.

6. When the liquid level lowers to a point where the float is no longer buoyant, the float drops, unsealing the air release sealing assembly. The air release orifice opens and allows part of the air that accumulated in the upper portion of the valve to be released to the atmosphere.

7. Liquid enters the valve. The float rises, pushing the air release sealing assembly to its sealing position. The remaining air gap prevents the wastewater from fouling the mechanism.

When internal pressure falls below atmospheric pressure (negative pressure):

1. The float will drop down, immediately opening the air & vacuum and air release orifices.
2. Air will enter into the system.

Main Features

- Working pressure range: 2", 4", 6", 8": 0.1 - 16 bar
- 3" metal : 0.2 - 16 bar, 0.2 - 25 bar
- 3" RN : 0.02-10 bar, 0.1 - 16 bar

- Testing pressure: 1.5 times the max. working pressure.

- Maximum working temperature: 60° C.

- Maximum intermittent temperature: 90° C.

- The unique design of the valve prevents contact between the wastewater and the sealing mechanism by creating an air gap at the top of the valve. These features are achieved by:

- **The conical body shape and the external guide rod/disc arm:** designed to maintain the maximum distance between the liquid and the sealing mechanism and still obtain minimum body length.

- **Spring-guided linkage between the float/rod assembly and the sealing mechanism:** allows free movement of the float and rod. Vibrations and movement of the float due to turbulence will not unseal the sealing mechanism.

- **Funnel-shaped lower body:** designed to ensure that residue wastewater matter will fall back into the system and be carried away by the main pipe.

- All inner metal parts made of stainless steel.

- Discharge outlet enables connection of a vent pipe.

- The ball valve can be opened to release trapped pressure and drain the valve body prior to maintenance and for back-flushing during maintenance.

Valve Selection

- Size availability: 2" - 8".
- Valve manufactured with flanged ends to meet any requested standard.
- Optional Covers (for air discharge direction and for add-on components):
 - 2" models - 2-directional cover is standard
 - 3" models - optional 1-directional and 2-directional cover
 - 4" models - 1-directional elbow for horizontal discharge can be removed to allow for vertical discharge
- Optional Add-on Components (2", 3", 4" sizes only)
 - With a **One-way**, Out-only attachment, allows for air discharge only, prevents air intake.
 - With a **Vacuum Breaker**, In-only attachment, allows for air intake only, prevents air discharge.
 - With a **Non-Slam** discharge-throttling attachment, allows for free air intake, throttles air discharge.
- Standard cast ductile (2" reinforced nylon body), also available with a stainless steel body and polyethylene cover.

- Valve body coating: fusion bonded epoxy coating in compliance with the standard DIN 30677-2.
- Other coatings are available upon request.

Note

- The D-26 air valve is intended for use with raw wastewater. For use with aggressive liquids, please consult with our application engineers or with the marketing dept.
- For best suitability, it is recommended to send the fluid chemical properties along with the valve request.
- Upon ordering, please specify: model, size, working pressure, thread and flange standard and type of liquid.

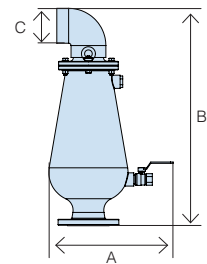

DIMENSIONS AND WEIGHTS

Model	Dimensions mm		Connection C	Weight Kg.		Orifice Area mm ²	
	A	B		RN	ST ST	A / V	Auto.
D-26 2" (50 mm) Threaded	258	547	2" BSP / NPSM Female	8.1	13.2	1963	8.6
D-26 2" (50 mm) Flanged	258	554	2" BSP / NPSM Female	8.5	16.1	1963	8.6
D-26 NS 2" (50 mm) Threaded	330	547	2" BSP / NPSM Male	8.3	13.6	1963	8.6
D-26 NS 2" (50 mm) Flanged	330	554	2" BSP / NPSM Male	8.7	16.5	1963	8.6
one-directional cover				DI	ST ST		
D-26 3" (80 mm) Threaded	526	580	3" BSP / NPSM Female	21.0	21.6	5024	15.7
D-26 3" (80 mm) Flanged	526	580	3" BSP / NPSM Female	21.6	24.6	5024	15.7
D-26 NS 3" (80 mm) Threaded	548	580	3" BSP / NPSM Male	21.8	22.5	5024	15.7
D-26 NS 3" (80 mm) Flanged	548	580	3" BSP / NPSM Male	24.7	25.5	5024	15.7
two-directional cover				DI	ST ST		
D-26 3" (80 mm) Threaded	495	620	3" BSP / NPSM Female	21.8	22.5	5024	15.7
D-26 3" (80 mm) Flanged	495	620	3" BSP / NPSM Female	24.2	25.0	5024	15.7
D-26 NS 3" (80 mm) Threaded	605	620	3" BSP / NPSM Male	22.7	23.4	5024	15.7
D-26 NS 3" (80 mm) Flanged	605	620	3" BSP / NPSM Male	24.7	25.4	5024	15.7
RN two-directional cover				RN			
D-26 3" (80 mm) Threaded	350	613	3" BSP / NPSM Female	14.6		5024	15.7
D-26 3" (80 mm) Flanged	350	625	3" BSP / NPSM Female	15.4		5024	15.7
D-26 NS 3" (80 mm) Threaded	436	613	3" BSP / NPSM Male	15.4		5024	15.7
D-26 NS 3" (80 mm) Flanged	436	625	3" BSP / NPSM Male	16.1		5024	15.7
				DI	ST ST		
D-26 4" (100 mm) Flanged	420	830	4" Flanged BSP / NPSM Female	43.6	45	7854	31.14
D-26 NS 4" (100 mm) Flanged	607	849	4" Flanged BSP / NPSM Female	48.5	50	7854	31.14
				DI	ST ST		
D-26 6" (150 mm) Flanged	545	889	6" Flanged BSP / NPSM Female	86.3	89.0	17671	31.14
D-26 NS 6" (150 mm) Flanged	545	1002	6" Flanged BSP / NPSM Female	91.2	94.0	17671	31.14
				DI	ST ST		
D-26 8" (200 mm) Flanged	552	1197	8" Flanged BSP / NPSM Female	127.2	141.5	31400	31.14
D-26 NS 8" (200 mm) Flanged	552	1337	8" Flanged BSP / NPSM Female	140.8	151.2	31400	31.14

NS Non-Slam Add-on Component Data Table for Variable Orifices

Nominal Size	Number of orifices	Discharge orifice (mm)	Total NS area (mm ²)	NS orifice (mm)	Switching point (bar)	Flow at 0.4 bar (m ³ /h)
2" (50mm)	1 orifice	50	15.9	4.5	Spring loaded normally closed	24
	2 orifices	50	31.8	6.4		31.6
	3 orifices	50	47.7	7.8		40
3" (80mm)	1 orifice	75	50.3	8	Spring loaded normally closed	38.47
	2 orifices	75	100.5	11.3		72.51
	3 orifices	75	150.8	13.9		111.38
4" (100mm)	1 orifice	100	78.5	10	Spring loaded normally closed	150
	2 orifices	100	157.1	14.1		185
	3 orifices	100	235.6	17.3		230
6" (150mm)	1 orifice with graduated closure	150	706.86	30	0.025	1580
8" (200mm)		200	1641.3	45.7	0.0025	1890

D-26 2"

AIR & VACUUM FLOW RATE

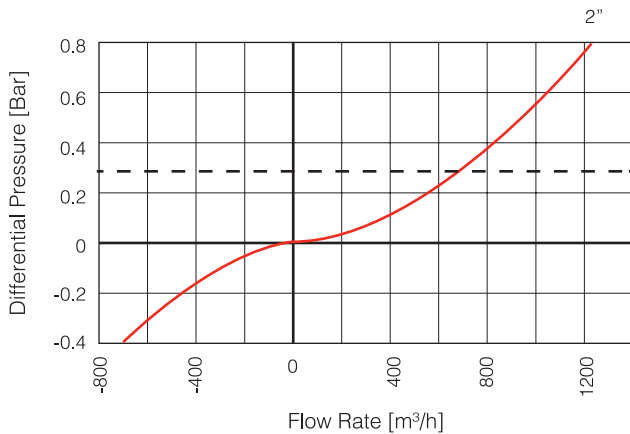

AUTOMATIC AIR RELEASE FLOW RATE

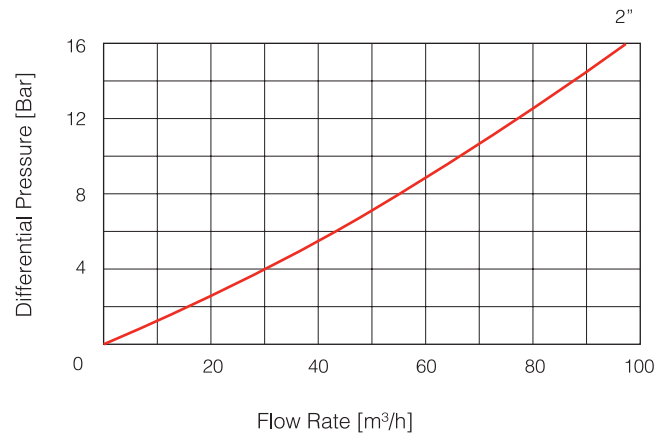

D-26 NS 2"

2" WITH ADJUSTABLE NS CHECK VALVE

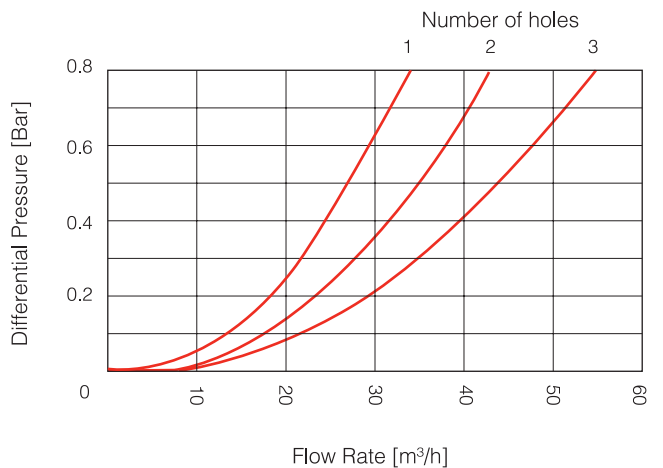
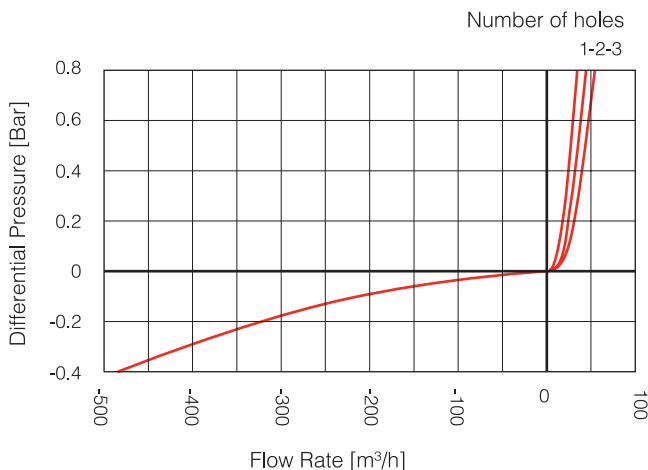

D-26 3"

AIR & VACUUM FLOW RATE

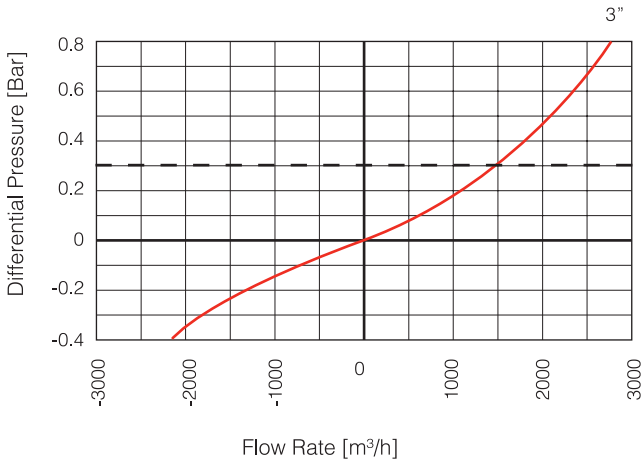

--- Max. recommended design air discharge

AUTOMATIC AIR RELEASE FLOW RATE

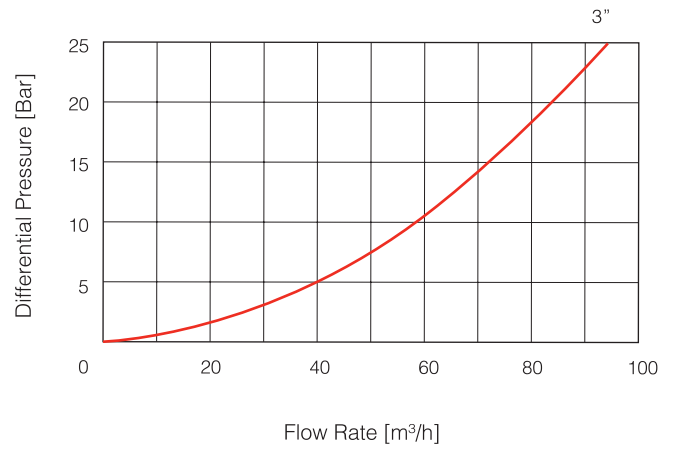

D-26 NS 3"

3" WITH ADJUSTABLE NS CHECK VALVE

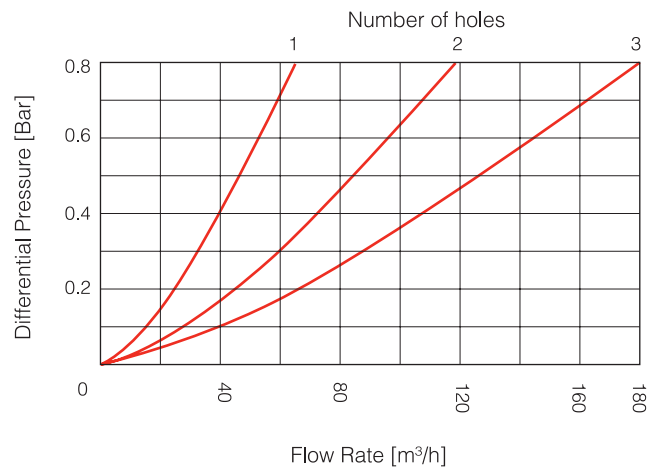
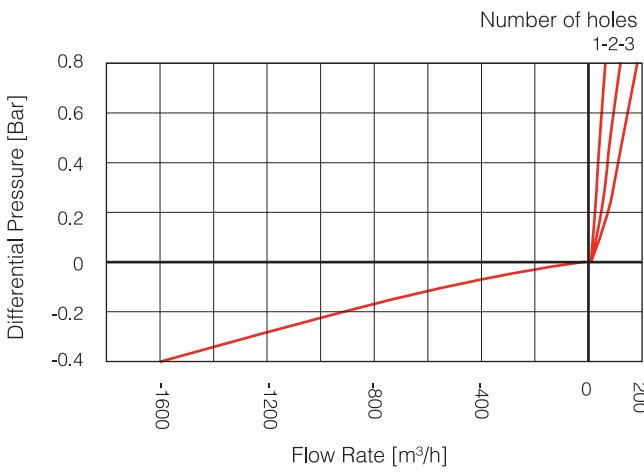

D-26 4"

AIR & VACUUM FLOW RATE

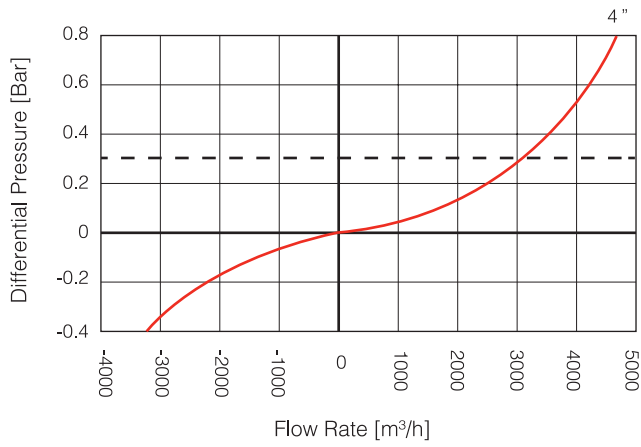

--- Max. recommended design air discharge

AUTOMATIC AIR RELEASE FLOW RATE

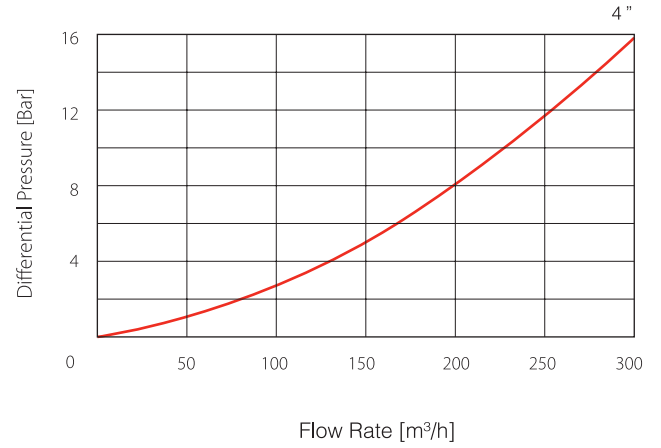

D-26 NS 4"

4" WITH ADJUSTABLE NS CHECK VALVE

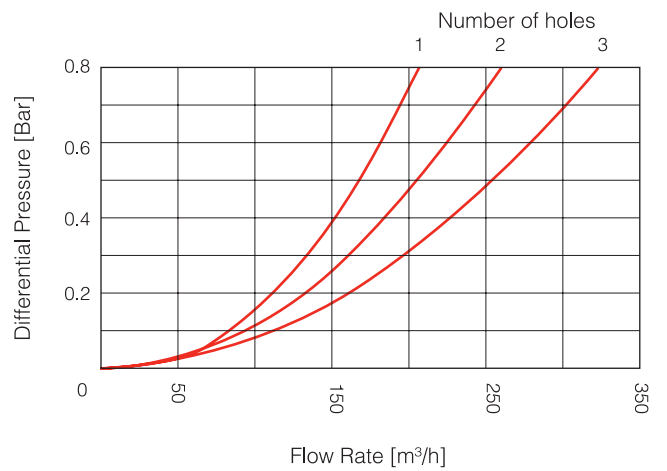
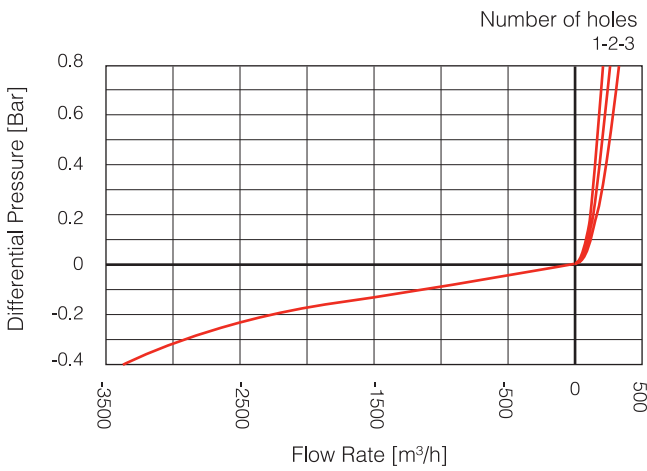

D-26 6"

AIR & VACUUM FLOW RATE

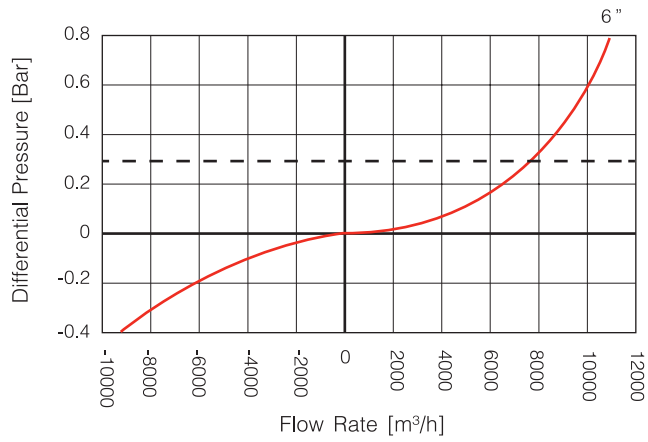

--- Max. recommended design air discharge

AUTOMATIC AIR RELEASE FLOW RATE

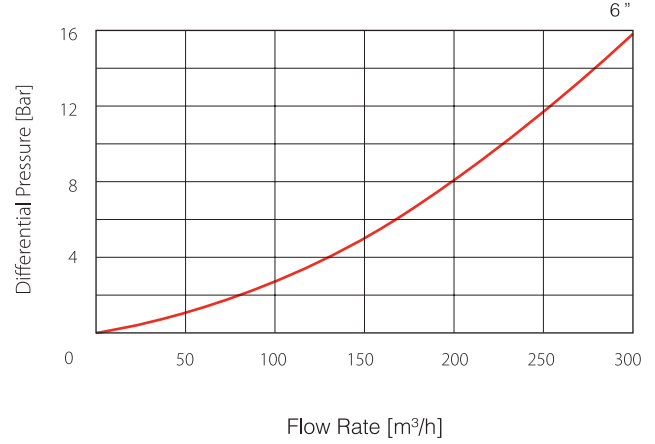

D-26 NS 6"

6" AIR & VACUUM FLOW RATE

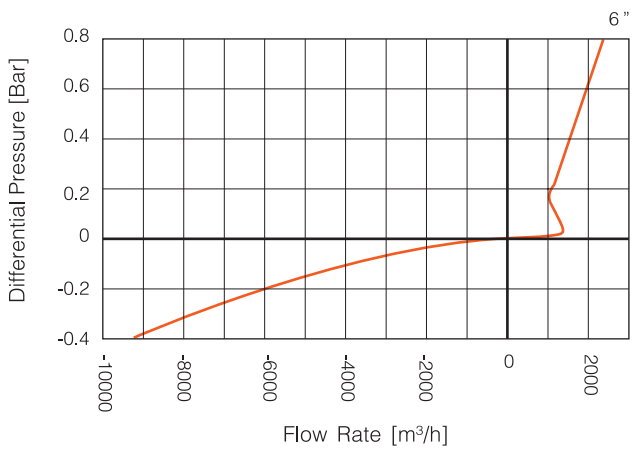

AIR DISCHARGE SWITCHING REGION

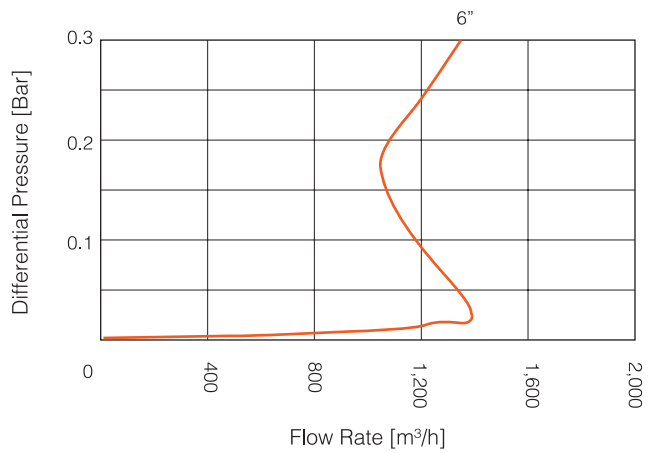

D-26 8"

AIR & VACUUM FLOW RATE

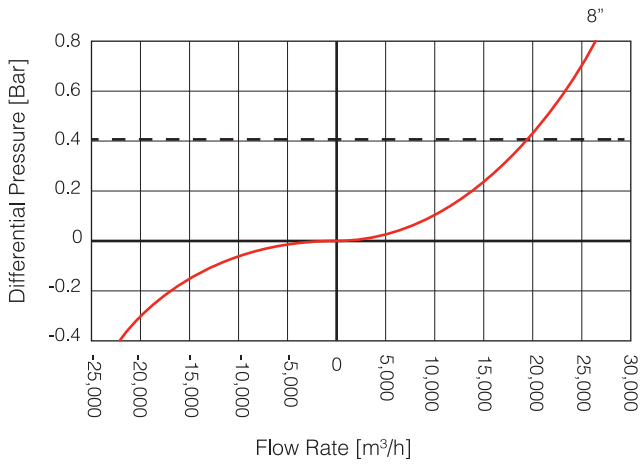

--- Max. recommended design air discharge

AUTOMATIC AIR RELEASE FLOW RATE

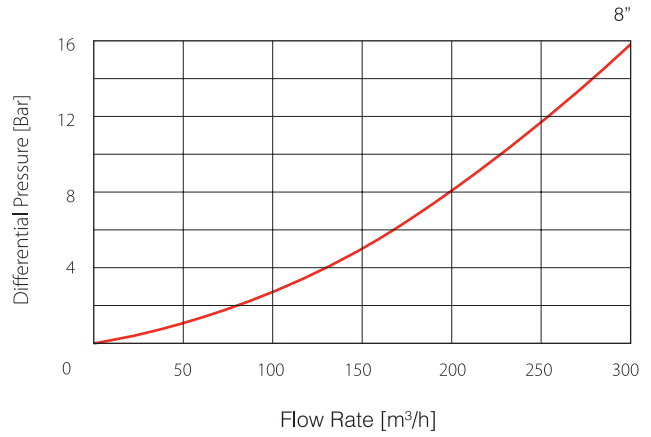

D-26 NS 8"

AIR & VACUUM FLOW RATE

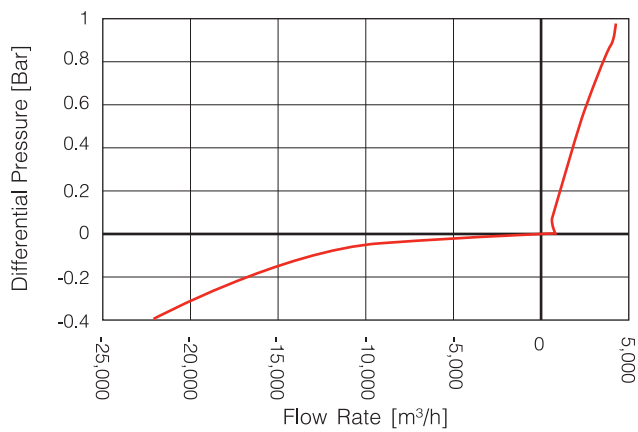

AIR DISCHARGE SWITCHING REGION

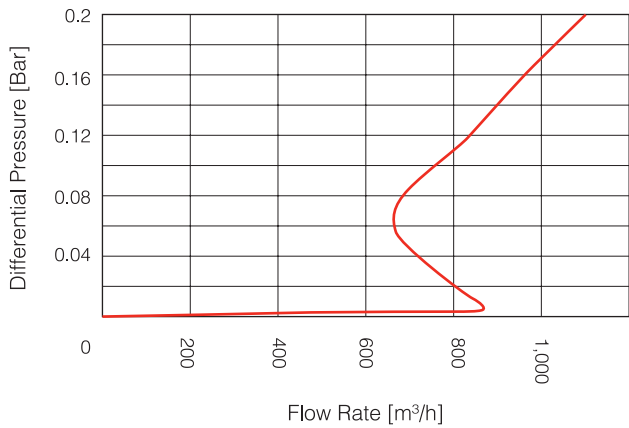

D-26 2" PARTS LIST AND SPECIFICATION

No.	Part	Material
1.	Threaded Plug	Polypropylene
2.	Cover	Stainless Steel SAE 316
3.	Disk Arm Assy.	Cast ST ST
4.	O-ring	BUNA-N
5.	Air & Vacuum Seal	EPDM
6.	Air Release Seal	EPDM
7.	Spring	Stainless Steel SAE 316
8.	Spray Guard*	Polypropylene
9.	Body	Reinforced Nylon / Stainless Steel SAE 316
10.	Float	Polypropylene
11.	Clamp	Cast Stainless Steel
12.	O-ring	BUNA-N
13.	Tap	Brass / Stainless Steel
14.	Base	Reinforced Nylon / Stainless Steel SAE 316
15.	NS Component	

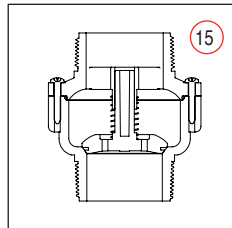
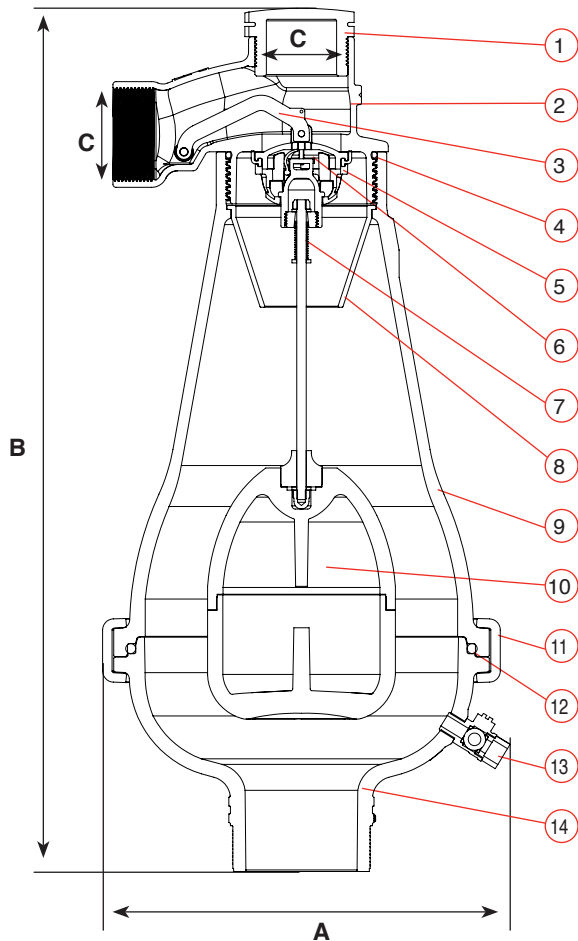

D-26 3" PARTS LIST AND SPECIFICATION - METAL BODY

No.	Parts	Material
1.	Disk Arm Assembly	Cast ST ST + EPDM
2.	Cover	Ductile Iron / ST ST 316
3.	Orifice Seat	ST ST 316
4.	Plug	Polypropylene
5.	Air & Vacuum Disc	Cast ST ST
6.	Air Release Seal	EPDM
7.	Bolt, Nut & Washer	ST ST 316
8.	O-ring	BUNA-N
9.	Air & Vacuum Seal	EPDM
10.	Spray Guard®	Polypropylene
11.	Spring	ST ST 316
12.	Body	Cast Steel / ST ST 316
13.	Float Assy.	Polypropylene + ST ST 316
14.	Ball Valve	Brass, Chrome Coated / ST ST 316
15.	NS Component	

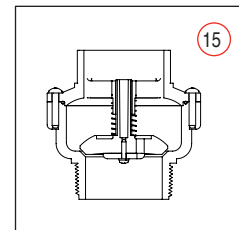
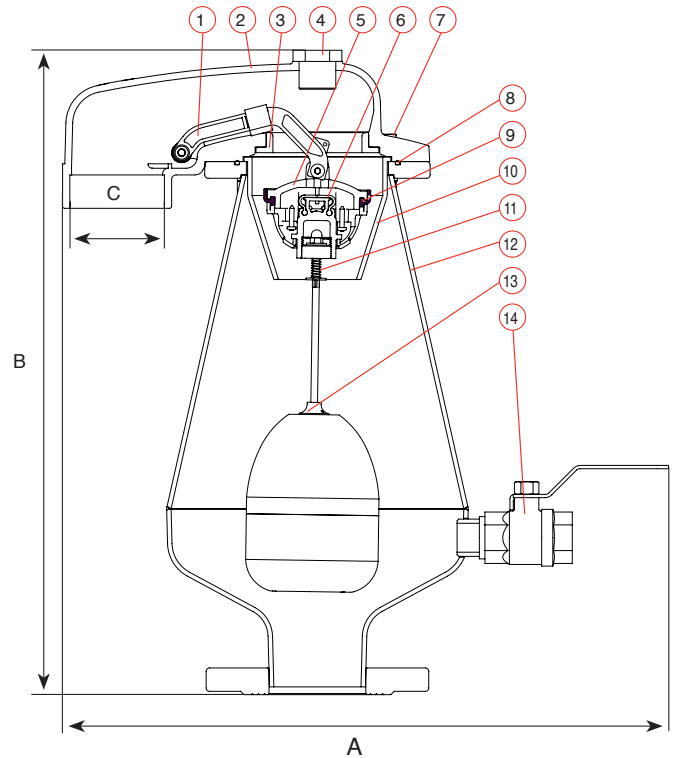

D-26 3" PARTS LIST AND SPECIFICATION - RN BODY

No.	Part	Material
1.	Threaded Plug	Polypropylene
2.	Cover	Stainless Steel SAE 316
3.	Disk Arm Assy.	Cast ST ST
4.	O-ring	BUNA-N
5.	Air & Vacuum Seal	EPDM
6.	Air Release Seal	EPDM
7.	Spring	Stainless Steel SAE 316
8.	Spray Guard®	Polypropylene
9.	Body	Reinforced Nylon
10.	Float	Polypropylene
11.	Clamp	Cast Stainless Steel
12.	O-ring	BUNA-N
13.	Ball Valve	Brass, Chrome Coated / ST ST 316
14.	Base	Reinforced Nylon
15.	NS Component	

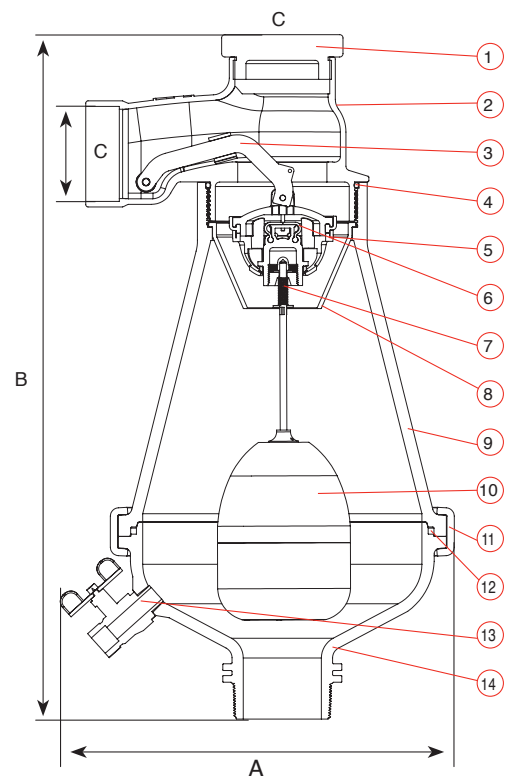

D-26 4" PARTS LIST AND SPECIFICATION

No.	Part	Material
1.	Discharge Elbow	PVC
2.	Spring	Stainless Steel SAE 302
3.	Bolt Nut & Washer	Stainless Steel SAE 316
4.	Cover	Ductile Iron / Stainless Steel SAE 316
5.	O-ring	NBR
6.	Guide Rod Assembly	Stainless Steel SAE 316
7.	Plug	Stainless Steel SAE 316
8.	Air & Vacuum Seal Assy.	EPDM + RN + ST. ST. 304 + Acetal
9.	Air Release Seal	EPDM
10.	Domed Nut	Stainless Steel SAE 316
11.	Flow Enhancer	ABS
12.	Spring	Stainless Steel SAE 302
13.	Float Assembly	Stainless Steel SAE 316
14.	Ball Valve	Stainless Steel SAE 316 / Reinforced Nylon
15.	Body	Ductile Iron / Stainless Steel SAE 316
16.	NS Component	

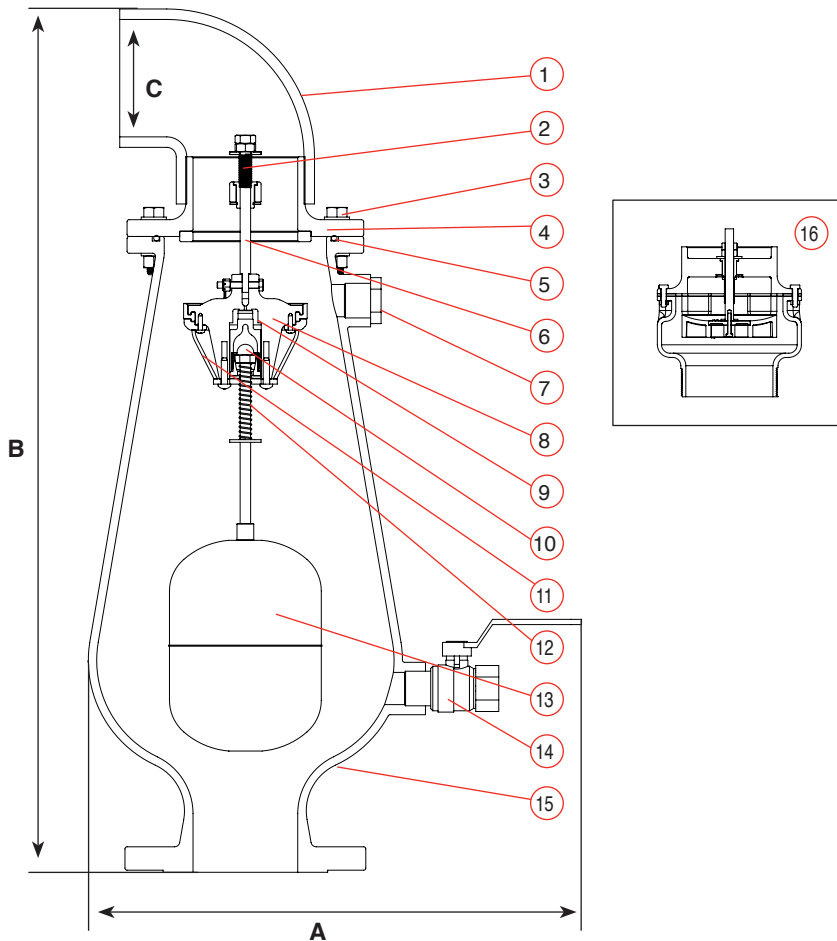

D-26 6" PARTS LIST AND SPECIFICATION

No.	Part	Material
1.	Flange Supports	Stainless Steel SAE 304
2.	Bolt and Washers	Stainless Steel SAE 316
3.	Discharge Elbow	Polyethylene
4.	Spring	Stainless Steel SAE 302
5.	Seal	NBR
6.	Cover	Ductile Iron / Stainless Steel SAE 316
7.	Bolt, Nut and Washer	Stainless Steel SAE 316
8.	O-ring	NBR
9.	Guide Rod Assy.	Stainless Steel SAE 316
10.	Air Release Seal	EPDM
11.	Air & Vacuum Seal Assy.	RN / EPDM / Stainless Steel SAE 316
12.	Flow Enhancer	ABS
13.	Domed Nut	Stainless Steel SAE 316
14.	Spring	Stainless Steel SAE 302
15.	Body	Ductile Iron / Stainless Steel SAE 316
16.	Float Assembly	Stainless Steel SAE 316
17.	Ball Valve	Stainless Steel SAE 316 / Reinforced Nylon

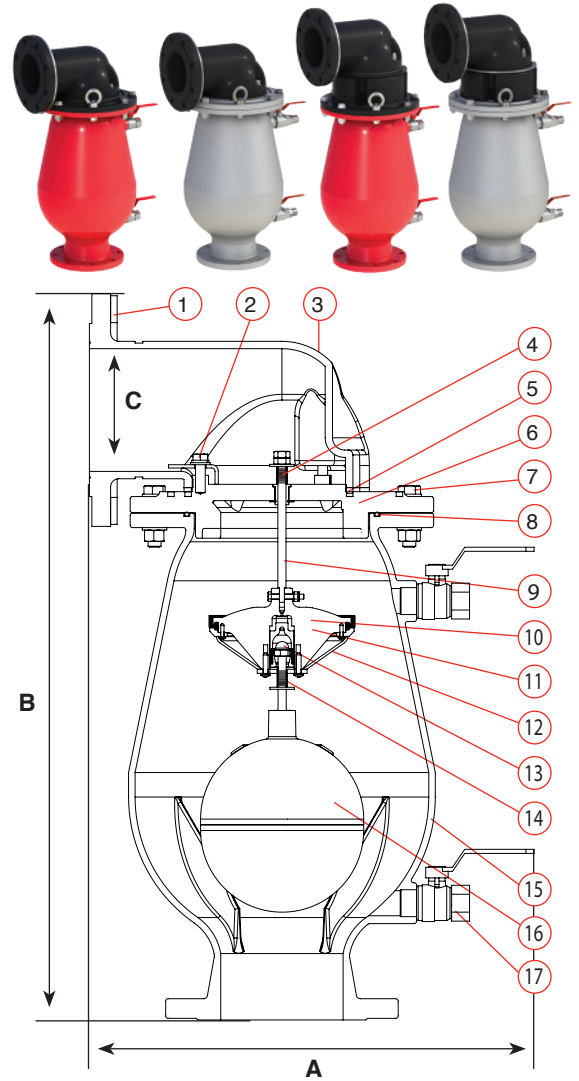

D-26 NS 6" PARTS LIST AND SPECIFICATION

No.	Part	Material
1.	Flange Supports	Stainless Steel SAE 304
2.	Discharge Elbow	Polyethylene
3.	Domed Nut and Washers	Stainless Steel SAE 316
4.	Threaded Rod	Stainless Steel SAE 304
5.	Ring	Stainless Steel SAE 316
6.	Ring Seal	EPDM
7.	Non Slam Disc	Stainless Steel SAE 316 / Ductil Iron
8.	Disc Housing	Polyethylene
9.	Spring	Stainless Steel SAE 302
10.	Cover	Ductile Iron / Stainless Steel SAE 316
11.	O-ring	NBR
12.	Bolt, Nut and Washer	Stainless Steel SAE 316
13.	O-ring	BUNA-N
14.	Guide Rod Assy.	Stainless Steel SAE 316
15.	Air & Vacuum Seal Assy.	RN / EPDM / Stainless Steel SAE 316
16.	Flow Enhancer	ABS
17.	Air Release Seal	EPDM
18.	Domed Nut	Stainless Steel SAE 316
19.	Spring	Stainless Steel SAE 302
20.	Body	Ductile Iron / Stainless Steel SAE 316
21.	Ball Valve	Stainless Steel SAE 316 / Reinforced Nylon
22.	Float Assembly	Stainless Steel SAE 316

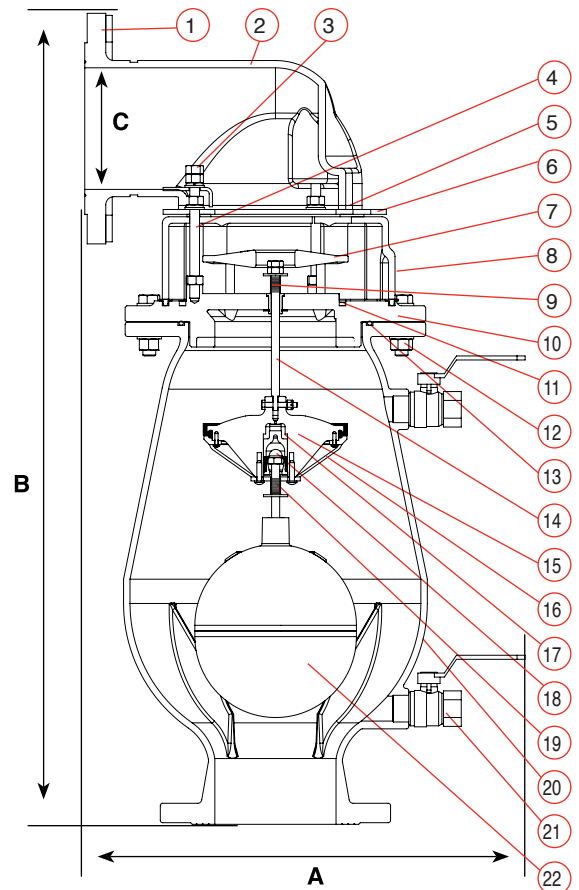

D-26 8" PARTS LIST AND SPECIFICATION

No.	Part	Material
1.	Flange Supports	Stainless Steel SAE 316
2.	Discharge Outlet Elbow	Polyethylene
3.	Nuts and Washers	Stainless Steel SAE 316
4.	Bolt, Nut and Washer	Stainless Steel SAE 316
5.	Cover	Ductile Iron / Stainless Steel SAE 316
6.	O-Ring	NBR
7.	Ball Valve	Reinforced Nylon
8.	Body	Ductile Iron / Stainless Steel SAE 316
9.	Float Assembly	Stainless Steel SAE 316 / Polycarbonate
10.	Ball Valve	Reinforced Nylon
11.	Spring	Stainless Steel SAE 302
12.	Guide Rod Assy.	Stainless Steel SAE 316
13.	Air & Vacuum Seal Assy.	RN / EPDM / ST. ST. SAE 316
14.	Air Release Seal	EPDM
15.	Domed Nut	Stainless Steel SAE 316
16.	Spring	Stainless Steel SAE 302

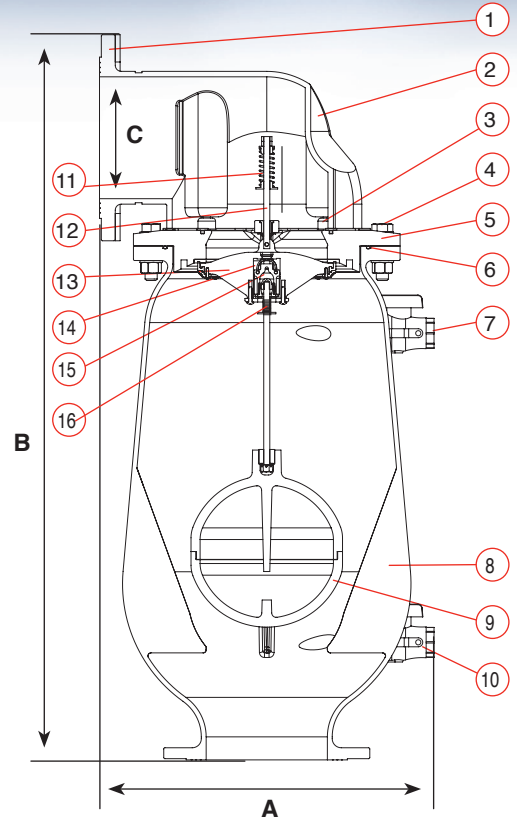

D-26 NS 8" PARTS LIST AND SPECIFICATION

No.	Part	Material
1.	Flange Supports	Stainless Steel SAE 316
2.	Discharge Outlet Elbow	Polyethylene
3.	Nuts and Washers	Stainless Steel SAE 316
4.	Ring	Stainless Steel SAE 316
5.	Ring Seal	EPDM
6.	Threaded Rod	Stainless Steel SAE 304
7.	Non Slam Disc	Ductile Iron / Stainless Steel SAE 316
8.	Disc Housing	Polyethylene
9.	Cover	Ductile Iron / Stainless Steel SAE 316
10.	O-Ring	NBR
11.	Seal	BUNA-N
12.	Ball Valve	Reinforced Nylon
13.	Body	Ductile Iron / Stainless Steel SAE 316
14.	Float Assembly	Stainless Steel SAE 316 / Polycarbonate
15.	Ball Valve	Reinforced Nylon
16.	Spring	Stainless Steel SAE 302
17.	Guide Rod Assy.	Stainless Steel SAE 316
18.	Bolt, Nut and Washer	Stainless Steel SAE 316
19.	Air & Vacuum Seal Assy.	RN / EPDM / ST. ST. SAE 316
20.	Air Release Seal	EPDM
21.	Domed Nut	Stainless Steel SAE 316
22.	Spring	Stainless Steel SAE 302

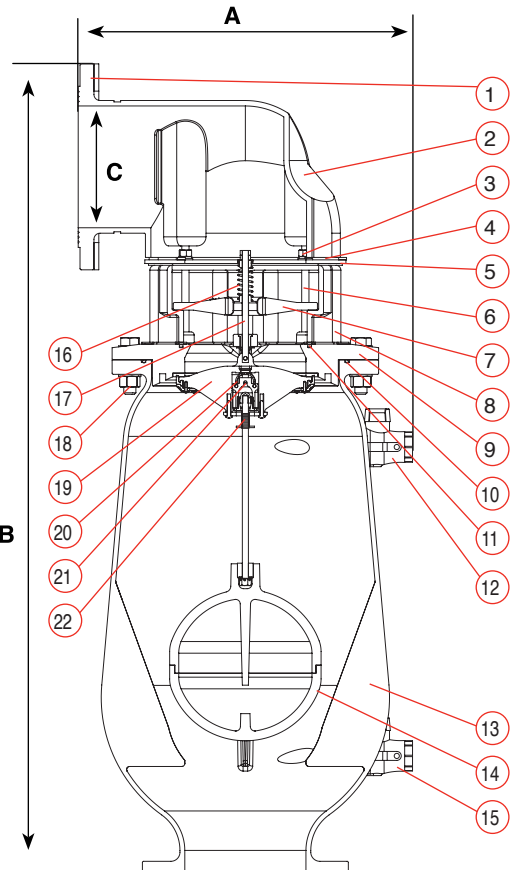

Pelmar Engineering Ltd.

Tel. (888) 754-6329, (416) 288-1736

E-mail: sales@pelmareng.com, www.pelmareng.com