

D-060

 PN 16

D-060-C

 PN 16

D-062

 PN 25

D-065

 PN 40

Combination Air Valve for High Flow

Description

The D-060 series Combination Air Valve has the features of both an air release valve and an air & vacuum valve.

The air release component is designed to automatically release small pockets of air to the atmosphere as they accumulate along a pipeline or piping system when it is full and operating under pressure.

The air & vacuum component is designed to automatically discharge or admit large volumes of air during the filling or draining of a pipeline or piping system. This valve will open to relieve negative pressures whenever water column separation occurs.

Applications

- Municipal and industrial water conveyance systems.

D-060-C, D-062, D-065 - additional applications

- Water pipelines vulnerable to vandalism and/or water theft.
- Water systems found in remote areas.
- Water systems with pressure demands of 25 & 40 bar (D-062 & D-065 respectively).

Operation

The air & vacuum component, with the large orifice, discharges air at high flow rates during the filling of the system and admits air into the system at high flow rates during its drainage and at water column separation.

High velocity air will not blow the float shut. Water will lift the float which seals the valve.

At any time during system operation, should internal pressure of the system fall below atmospheric pressure, air will enter the system.

The smooth discharge of air reduces pressure surges and other destructive phenomena.

The intake of air in response to negative pressure protects the system from destructive vacuum conditions and prevents damage caused by water column separation. Air entry is essential to efficiently drain the system.

The air release component releases entrapped air in pressurized systems.

Without air valves, pockets of accumulated air may cause the following hydraulic disturbances:

- Restriction of effective flow due to a reduction of the flow area. In

extreme cases this will cause complete flow stoppage.

- Obstruction of efficient hydraulic transmission due to air flow disturbances.
- Acceleration of cavitation damages.
- Increase in pressure transients and surges.
- Internal corrosion of pipes, fittings and accessories.
- Dangerous high-energy bursts of compressed air.
- Inaccuracies in flow metering.

As the system starts to fill, the combination air valve functions according to the following stages:

1. Air in the pipeline is discharged by the valve.
2. Liquid enters the air & vacuum component, lifting the float to its sealing position.
3. Liquid enters the air release component of the valve, lifting the float and pushing the rolling seal to its sealing position.
4. Entrapped air, accumulating at peaks and along the system, rises to the top of the air release valve, displacing the liquid in the valve's body.
5. The float drops, unsealing the rolling seal. The air release orifice opens and the accumulated air is released.
6. Liquid replaces the air released from the valve, buoying up the float and pushing the rolling seal back to its sealing position.

When internal pressure falls below atmospheric pressure (negative pressure):

1. The floats will drop down, immediately opening the air & vacuum and air release orifices.
2. Air will enter the system.

Main Features

- Working pressure range:
 - D-060 0.2 - 16 bar
 - D-060-C 0.2 - 16 bar
 - D-062 0.2 - 25 bar
 - D-065 0.2 - 40 bar
- Testing pressure for the air valve is 1.5 times its working pressure.
- Maximum working temperature: 60°C.
- Maximum intermittent temperature: 90°C.
- All main flow cross-sections are equal or greater than the nominal port area.

- Aerodynamic design enables high flow rates of air both at intake and at discharge.
- Reliable operation reduces water hammer incidents.
- Dynamic design allows for high capacity air discharge while preventing premature closure.
- Special orifice seat design: bronze and E.P.D.M. rubber, assures long-term maintenance-free operation.
- Screen protected outlet.
- The upper screen is protected with a protective cover.

Air Release Component

- Body made of high strength materials.
- All operating parts are made of specially selected corrosion-resistant polymer materials.
- Large size air release orifice:
 - Dramatically reduces the possibility of obstruction by debris.
 - Releases air at high flow rates.
 - One size orifice for a wide pressure range (up to 40 bar), achieved by the rolling seal mechanism.

Valve Selection

Size Range: 1" - 10"

2" - 8" (D-065 only)

D-060, rated for 16 bar.

D-060-C, vandalism protected by a metal shell covering the air release component, rated for 16 bar.

D-062, vandalism protected by a metal shell covering the air release component, rated for 25 bar.

D-065, rated for 40 bar.

- These valves are manufactured with flanged ends to meet any requested standard.
- The 1", 2" valves are also available with a threaded BSP or NPT connection.
- Valve coating: Fusion bonded epoxy coating according to the standard DIN 30677-2.
- Other coatings are available upon request.
- The air release component and the air & vacuum component are available as separate units.

Note

For best suitability, it is recommended to send the fluid chemical properties along with the valve request. Upon ordering, please specify: model, size, working pressure, thread and flange standard and type of liquid.

AIR & VACUUM FLOW RATE

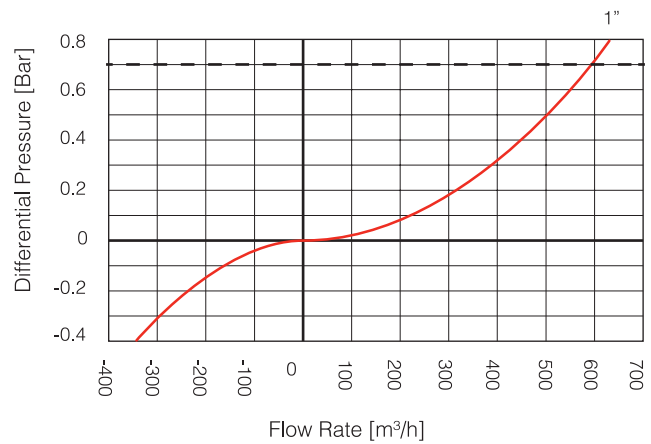

AIR & VACUUM FLOW RATE

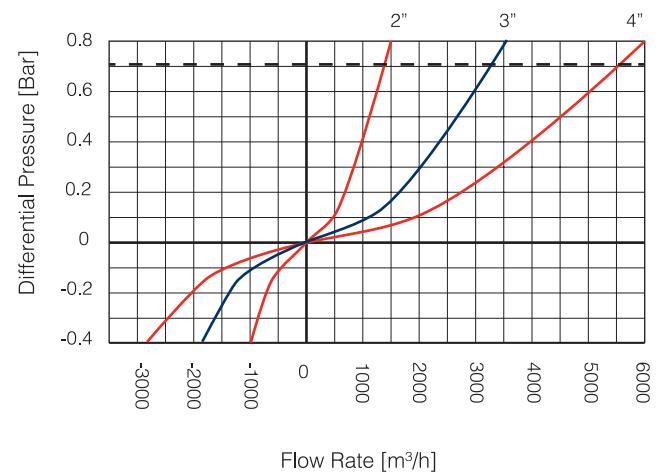

AIR & VACUUM FLOW RATE

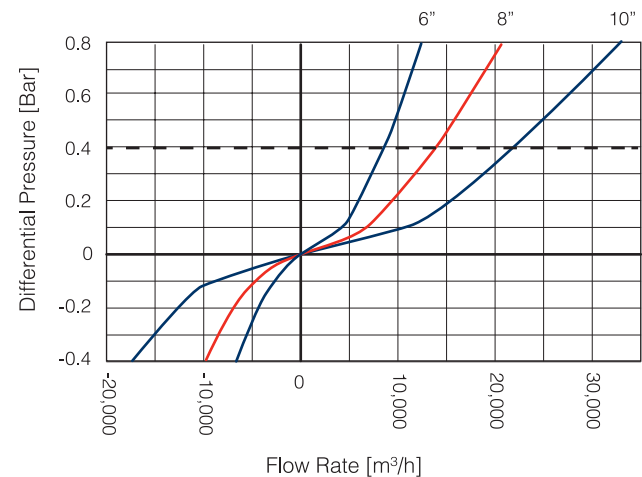

--- Max. recommended design air discharge

PN 16 AUTOMATIC AIR RELEASE FLOW RATE

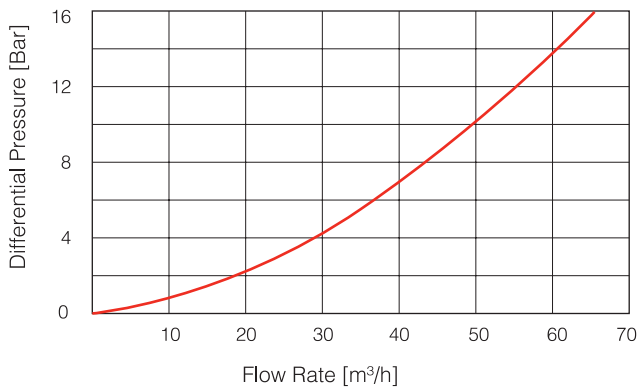

PN 25 AUTOMATIC AIR RELEASE FLOW RATE

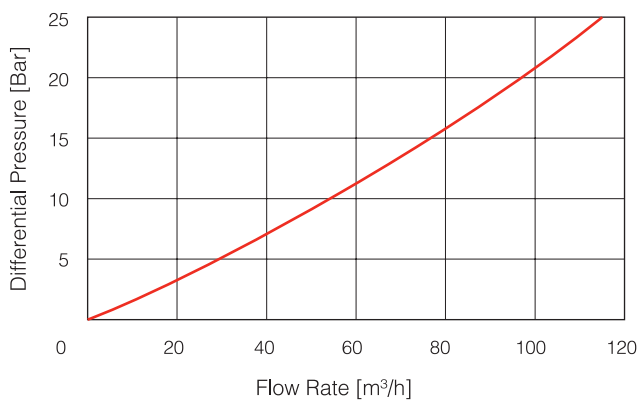

PN 40 AUTOMATIC AIR RELEASE FLOW RATE

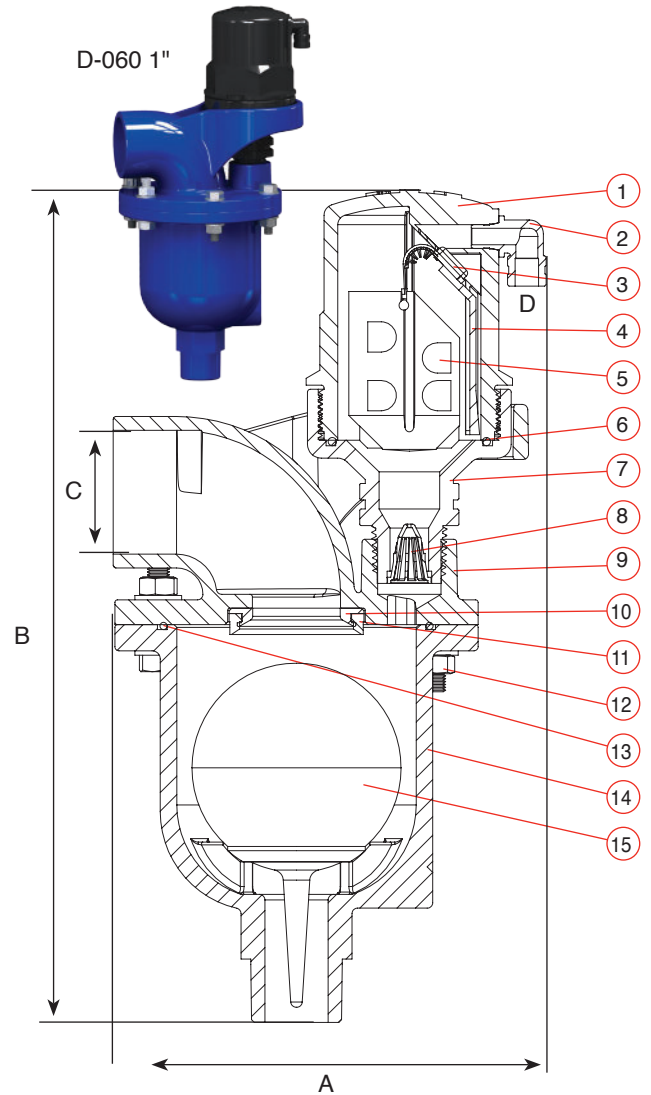
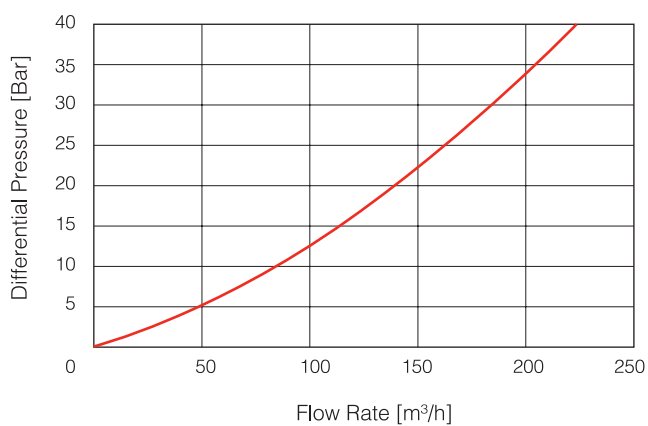

1" PARTS LIST AND SPECIFICATION

No.	Part	Material
1.	Body	Reinforced Nylon
2.	Discharge Outlet	Polypropylene
3.	Rolling Seal	EPDM
4.	Clamping Stem	Reinforced Nylon
5.	Float	Foamed Polypropylene
6.	O-Ring	BUNA-N
7.	Base	Reinforced Nylon
8.	Strainer	Nylon
9.	Cover	Ductile Iron
10.	Orifice Seat	Bronze
11.	Orifice Seal	EPDM
12.	Bolt, Nut & Washer	Steel, Zinc Cobalt Coated
13.	O-Ring	BUNA-N
14.	Body	Ductile Iron
15.	Float	Polycarbonate / Stainless Steel

DIMENSIONS AND WEIGHTS



Nominal Size	Dimensions mm		Connections		Weight Kg.	Orifice Area mm ²	
	A	B	C	D		A / V	Auto.
1" (25mm) Threaded	158	303	1½" Female	1/8" Female	4.4	506.7	12
1" (25mm) Flanged	158	303	1½" Female	1/8" Female	5.4	506.7	12

Nominal Size	Dimensions mm		Connection D	Weight Kg.	Orifice Area mm ²	
	A	B			A / V	Auto.
2" (50mm) Threaded	215	323	1/8" Female	9.7 - 10	1960	12
2" (50mm) Flanged	215	336	1/8" Female	10.7 - 11	1960	12
3" (80mm)	249	387	1/8" Female	17 - 18	5030	12
4" (100mm)	286	431	1/8" Female	23.6 - 25	7850	12
6" (150mm)	375	588	1/8" Female	73.5 - 78	17662	12
8" (200mm)	463	630	1/8" Female	108.6 - 117	31400	12
10" (250mm)	586	788	1/8" Female	137.7 - 150	49087	12

2"-10" PARTS LIST AND SPECIFICATION

No. Part	Material
1. Body	Reinforced Nylon
2. Air Release Outlet	Polypropylene
3. Rolling Seal	EPDM
4. Clamping Stem	Reinforced Nylon
5. Float	Foamed Polypropylene
6. O-Ring	BUNA-N
7. Base	Brass
8. Strainer	Nylon
9. Domed Nut & Washer	Stainless Steel 304
10. Screen Cover	2"-4" Ductile Iron 6"-10" Polyethylene / Ductile Iron
11. Threaded Rod	Stainless Steel 304
12. Screen	Stainless Steel 304
13. Cover	Ductile Iron
14. Bolt, Nut & Washer	Steel, Zinc Cobalt Coated
15. Orifice Seat	Bronze
16. Orifice Seal	EPDM
17. O-Ring	BUNA-N
18. Float	Polycarbonate / Stainless Steel
19. Body	Ductile Iron

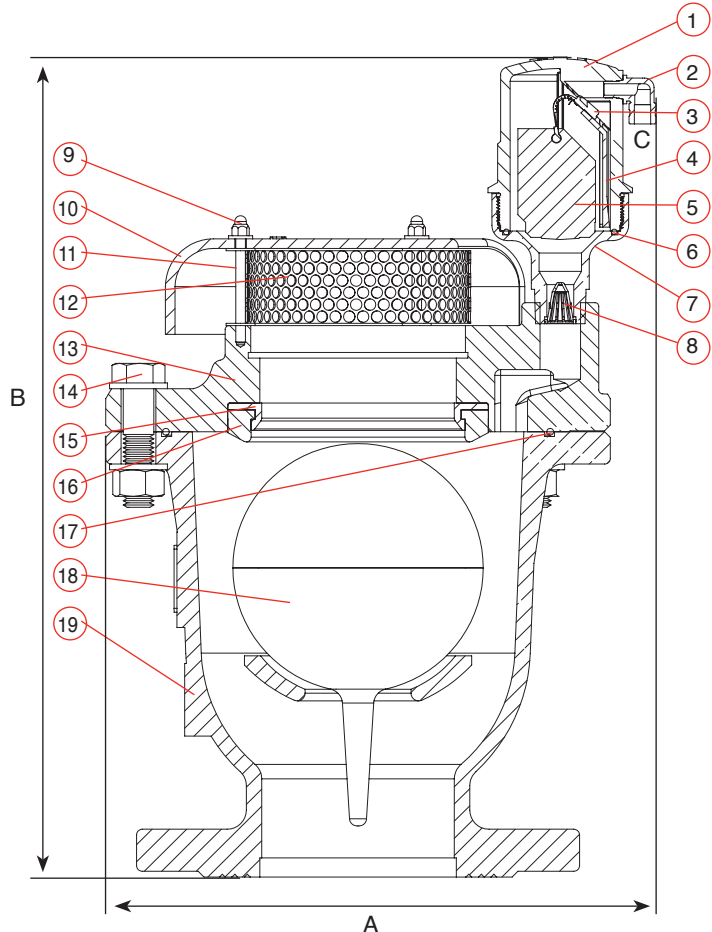



DIMENSIONS AND WEIGHTS

Nominal Size	Dimensions mm		Connections		Weight Kg.	Orifice Area mm ²		
	A	B	C	D		A / V	D-060-C Auto.	D-062
1" (25mm) Threaded	152	291	1½" Female	1/8" Female	5.3	506.7	12	9
1" (25mm) Flanged	152	311	1½" Female	1/8" Female	6.3	506.7	12	9

Nominal Size	Dimensions mm		Connection D	Weight Kg.	Orifice Area mm ²		
	A	B			A / V	D-060-C Auto.	D-062
2" (50mm) Threaded	210	357	1/8" Female	9.7 - 10	1960	12	9
2" (50mm) Flanged	210	325	1/8" Female	11.7 - 12	1960	12	9
3" (80mm)	243	393	1/8" Female	18 - 19	5030	12	9
4" (100mm)	280	438	1/8" Female	24.5 - 26	7850	12	9
6" (150mm)	375	596	1/8" Female	74.5 - 79	17662	12	9
8" (200mm)	463	638	1/8" Female	109.6 - 118	31400	12	9
10" (250mm)	586	788	1/8" Female	138.7 - 151	49087	12	9

PARTS LIST AND SPECIFICATION

No.	Part	Material
1.	Shell	Ductile Iron
2.	Body	Reinforced Nylon
3.	Air Release Outlet	Brass
4.	Rolling Seal	EPDM
5.	Float	Foamed Polypropylene
6.	Clamping Stem	Reinforced Nylon
7.	O-Ring	BUNA-N
8.	Base	Brass
9.	Strainer	Nylon
10.	Domed Nut & Washer	Stainless Steel 304
11.	Screen Cover	2"-4" Ductile Iron 6"-10" Polyethylene / Ductile Iron
12.	Threaded Rod	Stainless Steel 304
13.	Screen	Stainless Steel 304
14.	Cover	Ductile Iron
15.	Bolt, Nut & Washer	Steel, Zinc Cobalt Coated
16.	Orifice Seat	Bronze
17.	Orifice Seal	EPDM
18.	O-Ring	BUNA-N
19.	Float	Polycarbonate / Stainless Steel
20.	Body	Ductile Iron

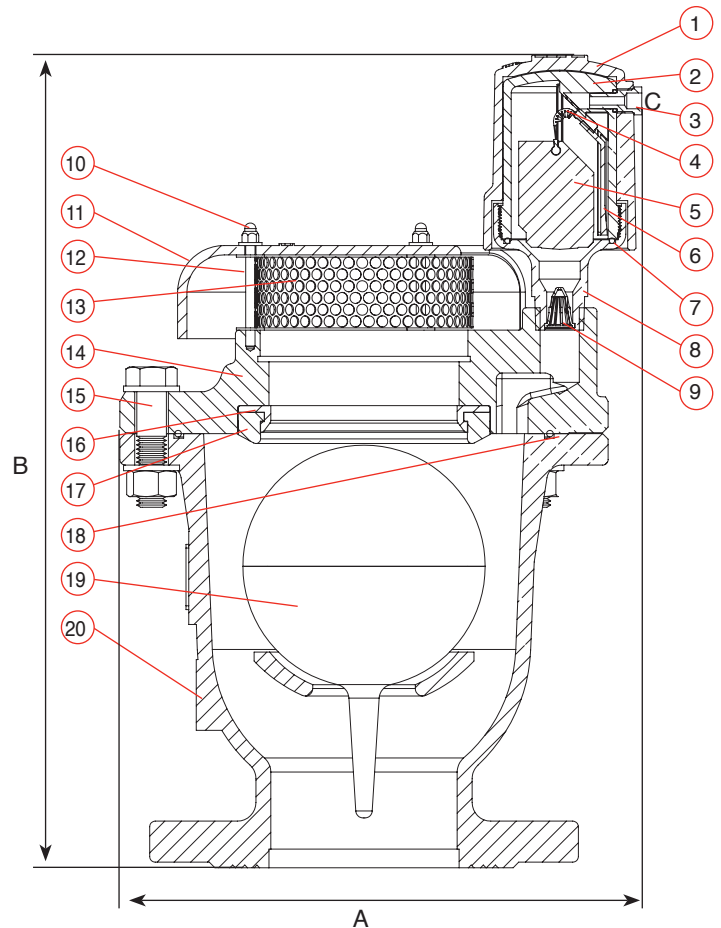

DIMENSIONS AND WEIGHTS

Nominal Size	Dimensions mm		Connection C	Weight Kg.	Orifice Area mm ²	
	A	B			A / V	Auto.
2" (50mm) Threaded	246	500	1/2" BSP Female	13.4 - 13.7	1960	15
2" (50mm) Flanged	246	487	1/2" BSP Female	15.4 - 15.7	1960	15
3" (80mm)	280	536	1/2" BSP Female	21.8 - 22.8	5030	15
4" (100mm)	317	580	1/2" BSP Female	28.2 - 29.6	7850	15
6" (150mm)	382	775	1/2" BSP Female	28.2 - 32.7	17662	15
8" (200mm)	472	813	1/2" BSP Female	109.4 - 121.7	31400	15



PARTS LIST AND SPECIFICATION

No. Part	Material
1. Air Release Outlet	PVC
2. Orifice	Reinforced Nylon
3. Rollpin	Stainless Steel 304
4. O-Ring	BUNA-N
5. Rolling Seal	EPDM
6. Rollpin	Stainless Steel 304
7. Lever	Reinforced Nylon
8. Rollpin	Stainless Steel SAE 304
9. Cover	Ductile Iron
10. O-Ring	BUNA-N
11. Bolt Nut & Washer	Steel, Zinc Cobalt Coated
12. Float	Polycarbonate / Stainless Steel
13. Body	Ductile Iron
14. Adaptor	Brass
15. Domed Nut & Washer	Stainless Steel 304
16. Screen Cover	2"-4" Ductile Iron 6"-8" Polyethylene / Ductile Iron
17. Threaded Rod	Stainless Steel 304
18. Screen	Stainless Steel 304
19. Cover	Ductile Iron
20. Bolt, Nut & Washer	Steel, Zinc Cobalt Coated
21. Orifice Seat	Bronze
22. Orifice Seal	EPDM
23. O-Ring	BUNA-N
24. Float	2"-4" Polycarbonate / Stainless Steel 304 6"-8" Stainless Steel
25. Body	Ductile Iron

