



# D-040

PATENTED



## Combination Air Valve “BARAK”

### Description

The D-040 Combination Air Valve has the features of both an Air-release valve and an Air/vacuum valve.

The Air-release component of the D-040 was designed to automatically release to the atmosphere small pockets of air as they accumulate along a pipeline when the pipeline or piping system is full and operating under pressure.

The Air/vacuum component was designed to automatically discharge or admit large volumes of air during the filling or draining of a pipeline or piping system. This valve will open to relieve negative pressures whenever water column separation occurs.

### Operation

The air & vacuum component, with the large orifice, discharges air at high flow rates during the filling of the system and admits air into the system at high flow rates during its drainage and at water column separation.

High velocity air, should not blow the float shut. Water will lift the float and cause sealing of the valve.

At any time during system operation, should internal pressure of the system fall below atmospheric pressure, air will re-enter the systems, preventing down-surge and cavitation.

The smooth release of air prevents pressure surges and other destructive phenomena.

Admitting air in response to negative pressure protects the system from destructive vacuum conditions, prevents damage caused by water column separation. Air re-entry is essential to efficiently drain the system.

The automatic small orifice air release component releases entrapped air in the pressurized systems.

**Without air valves pockets of accumulated air may cause the following destructive phenomena:**

- Obstruction to effective flow and hydraulic conductivity of the system along with a throttling effect similar to a partially closed valve. In extreme cases this will cause complete flow stoppage.
- Accelerate cavitation damages.
- High-pressure surges.
- Accelerate corrosion.
- Danger of a high-energy burst of compressed air.

**As the system starts to fill, the valve functions according to the following stages:**

1. Entrapped air is released by the valve
2. Liquid enters the valve, lifting the float which draws the "seal plug" to its sealing position.
3. Entrapped air, which accumulates at peaks along the system (where combination air valves should be installed), rises to the top of the valve, which in turn displaces the liquid in the valve's body.
4. The float descends, peeling the "rolling seal", the smaller orifice opens and the accumulated air is released.
5. Liquid penetrates into the valve and the float rises unrolling the rolling seal to its sealing position.

**When internal pressure falls below atmospheric pressure (negative pressure):**

1. Both orifices will be immediately unplugged and the float drops away.
2. Air is admitted to the system.

### Main Features

- Working pressure range: 3- 250 psi.
- Testing pressure: 360 psi.
- Working Temperature: 140° f.
- Maximum instantaneous working temperature: 194° f.
- Light, simple and reliable structure.
- The valve discharges air at high velocity, exceeding 11 psi differential pressure, without premature closing.
- The automatic air release orifice is very large relative to the size of the air valve body, therefore it discharges air at high flow rates.
- The size of the automatic orifice lessens the danger of its obstruction by debris.
- The rolling seal mechanism of the valve is less sensitive to pressure differential than a direct float seal. It is due to its comparably large orifice and its wide pressure range 3- 250 psi.
- The body is made of high strength composite materials and all operating parts are made of specially selected, corrosion resistant materials.
- Due to its light weight, the valve may be installed on plastic piping systems, as well as other lightweight piping.

### AIR & VACUUM FLOWRATE

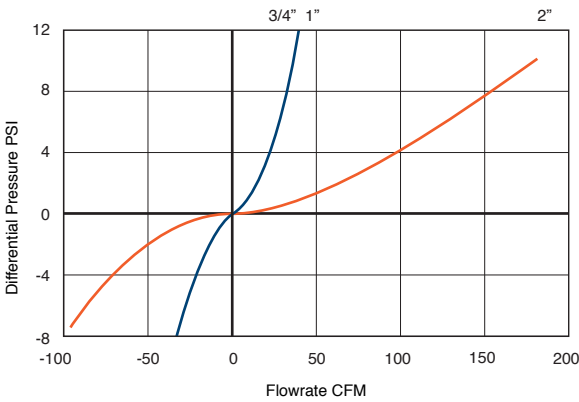

D-040 2"



D-040 ST 2"



D-040 T 2"

### AUTOMATIC AIR RELEASE

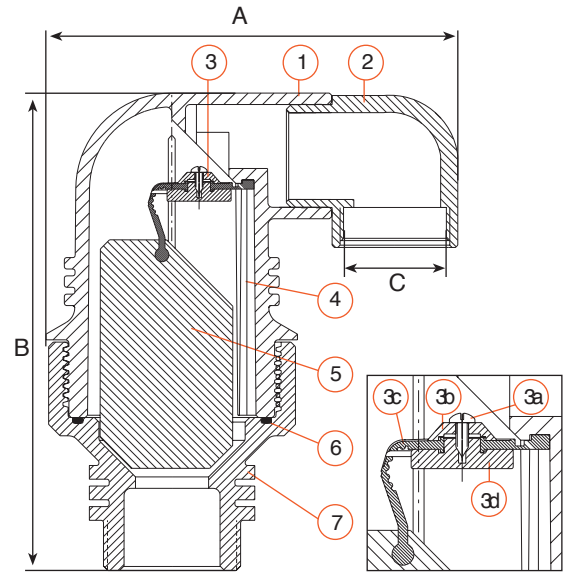
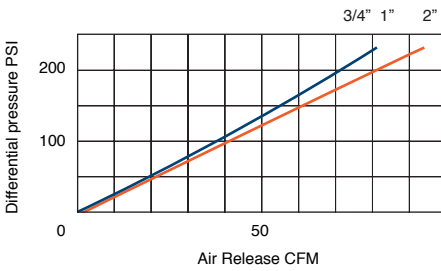

### DIMENSIONS AND WEIGHT

Nominal Size	Dimensions				Weight Lbs	Orifice Area Sq.in	
	A	B	internal C	external		Air & Vacu.	Auto.
D-040 3/4" 1"	3.9	5.5	3/8	0.86	0.73	0.155	0.012
D-040 2"	7	8.2	1 1/2	2.16	2.35	1.246	0.018
D-040 T 2"	5	8.2	1 1/2	2.16	2.2	1.246	0.018



D-040 3/4" 1"

### PARTS LIST AND SPECIFICATION

No.	Part	Material
1.	Body	NSF 61 Certified Reinforced Nylon
2.	Discharge outlet	NSF 61 Certified Polypropylene
3.	3/4" 1" Rolling Seal 2" Seal Plug Assembly	NSF 61 Certified E.P.D.M.
3a.	Screws	Stainless Steel
3b.	Plug Cover	NSF 61 Certified Reinforced Nylon
3c.	Rolling Seal	NSF 61 Certified E.P.D.M.
3d.	Plug	NSF 61 Certified Reinforced Nylon
4.	Clamping Stem	NSF 61 Certified Reinforced Nylon
5.	Float	NSF 61 Certified Foamed Polypropylene
6.	O - Ring	NSF 61 Certified NBR 70
7.	Base	NSF 61 Certified Reinforced Nylon

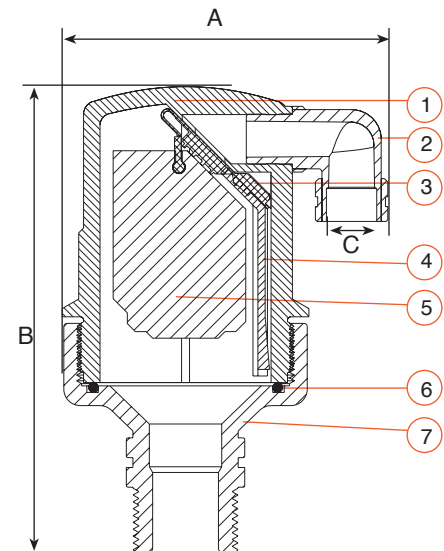

## AIR & VACUUM FLOWRATE

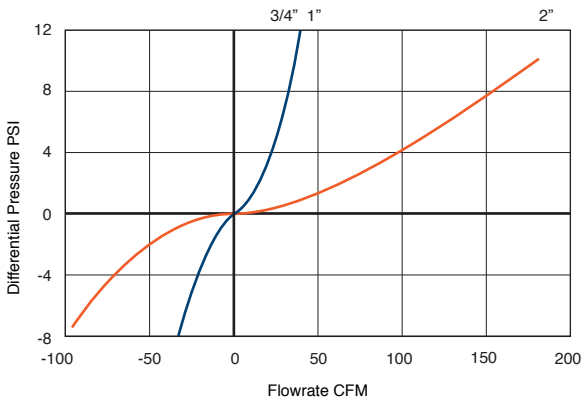

D-040-C



D-040-STST

## AUTOMATIC AIR RELEASE

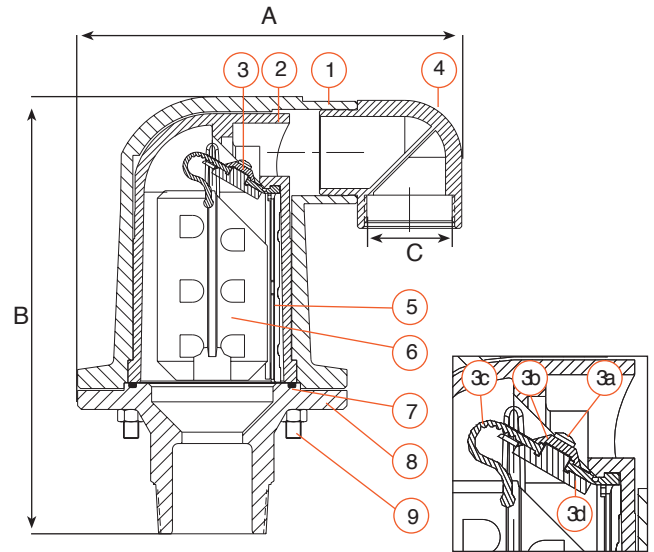
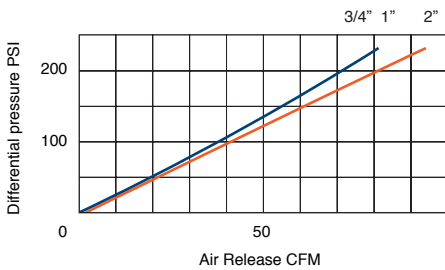

## DIMENSIONS AND WEIGHT

Nominal Size	Dimensions				Weight Lbs	Orifice Area Sq.in	
	A	B	internal C	externa		Air & Vacu.	Auto.
D-040-C 1"	4.7	5.9	3/8	0.86	3.75	0.127	0.0077
D-040-C 2"	8	9	1 1/2	2.16	11.9	1.246	0.0186
D-040 STST 2"	7.0	8.2	1 1/2	2.16	8.96	1.246	0.0186



D-040-C 3/4" 1"

## PARTS LIST AND SPECIFICATION

No.	Part	Material
1.	Body	Cast Iron ASTM A48 CL.35B
2.	Sleeve	NSF 61 Certified Reinforced Nylon
3.	3/4" 1" Rolling Seal	NSF 61 Certified E.P.D.M.
	2" Seal Plug Assembly	
3a.	Screws	Stainless Steel
3b.	Plug Cover	NSF 61 Certified Reinforced Nylon
3c.	Rolling Seal	NSF 61 Certified E.P.D.M.
3d.	Plug	NSF 61 Certified Reinforced Nylon
4.	Discharge outlet	NSF 61 Certified Polypropylene
5.	Clamping Stem	NSF 61 Certified Reinforced Nylon
6.	Float	NSF 61 Certified Foamed Polypropylene
7.	O - Ring	NSF 61 Certified NBR 70
8.	Base	3/4" 1" Stainless Steel ASTM A744 CF8M (NSF)
	2" Cast Iron ASTM A48 CL.35B	
9.	Bolts & Nuts	Stainless Steel ASTM A744 CF8M (NSF)

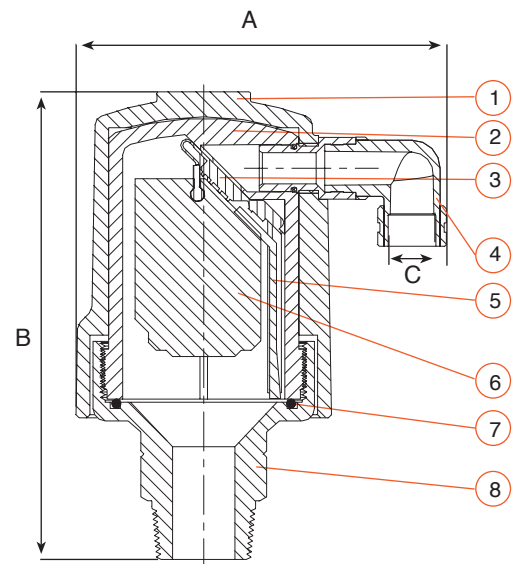

## Valve Selection

The D-040 air valve is available:

- With 3/4", 1" male NPT connections.
- With 2" female NPT connections.
- D-040 body made of composite materials.
- D-040-C with anti-vandalism cover.
- D-040 STST body made of Stainless Steel.
- D-040 ST with Stainless Steel base.

## ACCESSORIES

### One Way

D040-V -With a vacuum guarding, out-only attachment, which only allows air discharge, not allowing air intake (all models).

D-040-I -With a vacuum breaking, In-only attachment, which only allows air intake, not allowing air discharge (D-040 2" only).

D-040-NS -With a non-slam, discharge-throttling attachment, which allows free air intake, but throttles air discharge (D-040 2" only).

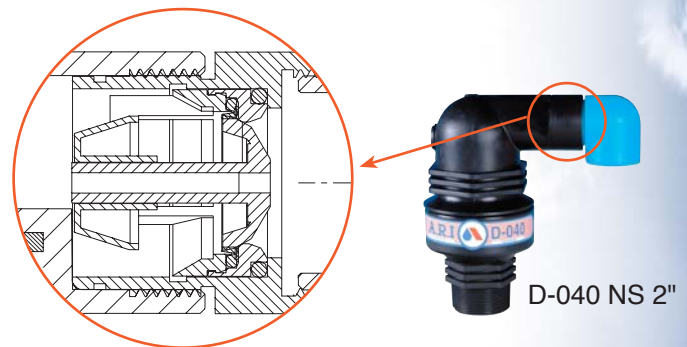

### Screen

Prevents penetration of debris and insects and can be assembled on the valve before or after the Discharge outlet.

Each strainer has 2 threaded connections 1.5" NPSM/ 2" NPSM .



### Air Valve Enclosure

A.R.I. air valve enclosure is used to protect air valve , for above surface air valve installations.

The special enclosure protects and hide the air valves from vandalism and damages.



**Pelmar Engineering Ltd.**

Tel. (888) 754-6329, (416) 288-1736 E-mail:

sales@pelmareng.com

Web site: www.pelmareng.com