

D-021 150 PSI



Combination Air Valve Reclaimed and Non-Potable Water

Description

The D-021 Combination Air Valve combines an air & vacuum component and an air release component in a single body. The valve is specifically designed to operate with liquids carrying low concentrations of solid particles such as reclaimed and non-potable water. The combination air valve discharges air (gas) during the filling or charging of the system, admits air into the system during drainage and at water column separation and releases accumulated air (gas) from the system while it is operating under pressure. The valve's unique design enables the separation of the liquid from the sealing mechanism and assures optimum working conditions

Applications

Water with low concentrations of suspended solids:

- Reclaimed water
- Raw water
- Effluent water
- Coolant water

Operation

The air & vacuum component discharges air at high flow rates during the filling of the system and admits air into the system at high flow rates during drainage and at water column separation.

High velocity air will not blow the float shut. Water will lift the float which activates the sealing of the valve.

At any time during system operation, should internal pressure of the system fall below atmospheric pressure, air will enter the system.

The smooth discharge of air reduces pressure surges and other destructive phenomena.

The intake of air in response to negative pressure protects the system from destructive vacuum conditions and prevents damage caused by water column separation. Air entry is essential to efficiently drain the system.

The air release component releases entrapped air in pressurized systems.

Without air valves, pockets of accumulated air may cause the following hydraulic disturbances:

- Restriction of effective flow due to a reduction of the flow area. In extreme cases this will cause complete flow stoppage.
- Obstruction of efficient hydraulic transmission due to air flow disturbances.

- Acceleration of cavitation damages.
- Increase in pressure transients and surges.
- Internal corrosion of pipes, fittings and accessories.
- Dangerous high-energy bursts of compressed air.
- Inaccuracies in flow metering.

As the system fills and is pressurized, the combination air valve functions according to the following stages:

1. Air (gas) is discharged by the valve
2. When the liquid level reaches the valve's lower portion, the lower float is lifted, pushing the sealing mechanism to its sealing position.
3. The entrapped air is confined in a pocket between the liquid and the sealing mechanism. The air pressure is equal to the system pressure.
4. Increases in system pressure compress the trapped air in the upper section of the conical chamber. The conical shape assures the height of the air gap. This enables separation of the liquid from the sealing mechanism.
5. Entrapped air (gas), accumulating at peaks and along the system, rises to the top of the valve and displaces the liquid in the valve's body.
6. When the liquid level lowers to a point where the float is no longer buoyant, the float drops, unsealing the rolling seal. The air release orifice opens and allows part of the air that accumulated in the upper portion of the valve to be released to the atmosphere.
7. Liquid enters the valve. The float rises, pushing the rolling seal to its sealing position. The remaining air gap prevents the wastewater from fouling the mechanism.

When internal pressure falls below atmospheric pressure (negative pressure):

1. The floats will drop down, immediately opening the air & vacuum and air release orifices.
2. Air will enter into the system.

Main Features

Main Features

- Working pressure range: 3 - 150 psi
- Testing pressure: 250 psi
- Maximum working temperature: 140° F.
- Maximum intermittent temperature: 194° F.
- The unique design of the valve prevents contact between the reclaimed water and the sealing mechanism by creating an air gap at the top of the valve. These features are achieved by:

- The conical body shape: designed to maintain the maximum distance between the liquid and the sealing mechanism and still obtain minimum body length.
 - Independent spring-guided linkage between the lower float/rod assembly and the upper float sealing mechanism: allows free movement of the float and rod. Vibrations and movement of the lower float due to turbulence will not unseal the upper float sealing mechanism
 - The Rolling Seal Mechanism: less sensitive to pressure differentials than a direct float seal. It accomplishes this by having a comparably large orifice for a wide pressure range (up to 150 psi).
 - Funnel-shaped lower body: designed to ensure that residue reclaimed water solid matter will fall back into the system and be carried away by the main pipe.
 - Body made of composite materials, resistant to corrosion.
 - Internal metal parts are made of corrosion-resistant stainless steel.
- Floats are made of composite materials.
- Flexible rolling seal provides smooth positive opening, closing, and leak-free sealing over a wide range of pressure differentials.
 - Drainage tap with ball valve is provided.
 - 3/8" threaded discharge outlet enables connection of a vent pipe.
 - Dynamic design allows for high capacity air discharge while preventing premature closure.
 - The ball valve can be opened to release trapped pressure and drain

the valve body prior to maintenance and for back-flushing during maintenance.

Valve Selection

- Size Range: 1" & 2" with a NPT male threaded connection or with flanged ends to meet any requested standard.
- Additional one-way out check valve attachment allows air discharge, not allowing air intake.

Note

- The D-021 air valve is intended for use with reclaimed and raw water. For use with aggressive liquids and liquids containing high concentrations of solid particles, please consult with our application engineers or with the marketing dept.
- For best suitability, it is recommended to send the fluid chemical properties along with the valve request.
- Upon ordering, please specify: model, size, working pressure, thread and flange standard and type of liquid.

DIMENSIONS AND WEIGHTS

Dimensions Inch		Connection	Weight Lbs.	Orifice Area Sq.In.	
A	B			Air Rel.	A / V
8.5	12.7	3/8" NPT Female	3.9	0.012	0.155

PARTS LIST AND SPECIFICATION

No. Part	Material
1. Body	Reinforced Nylon
2. Discharge Outlet	Polypropylene
3. Rolling Seal	E.P.D.M.
4. Clamping Stem	Reinforced Nylon
5. Float	Foamed Polypropylene
6. O-Ring	BUNA-N
7. Body	Reinforced Nylon
8. Float Stem	Stainless Steel SAE 316
9. Clamp	Reinforced Nylon + Stainless Steel SAE 316
10. O-Ring	BUNA-N
11. Float	Foamed Polypropylene
12. Base	Reinforced Nylon
13. Ball Valve 1/4"	Stainless Steel SAE 316

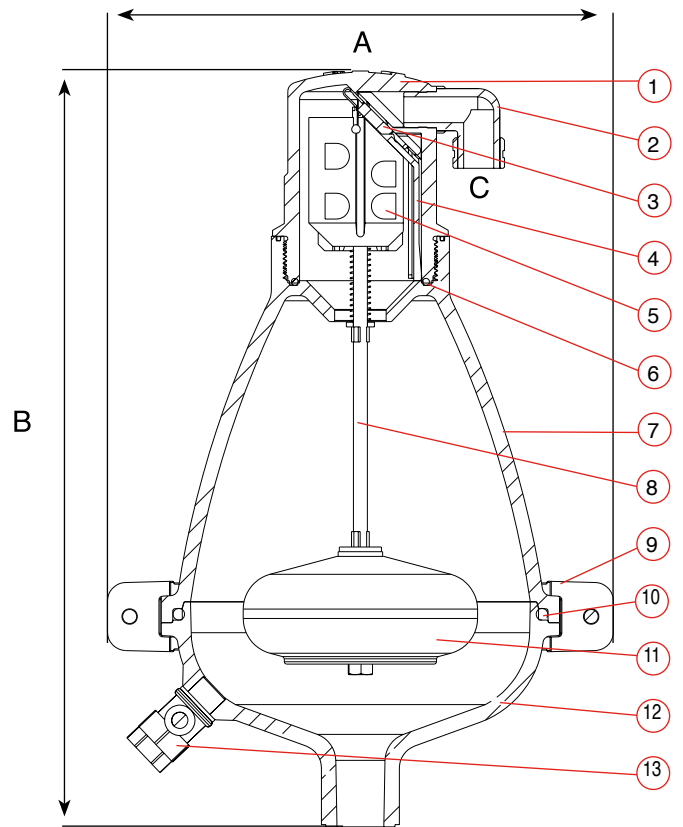

AIR & VACUUM FLOWRATE

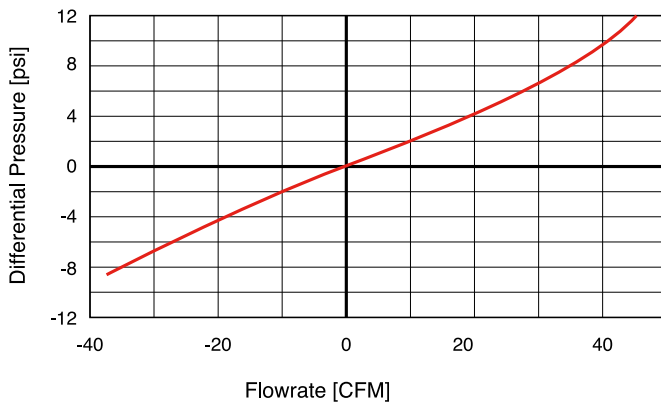

AIR RELEASE FLOWRATE

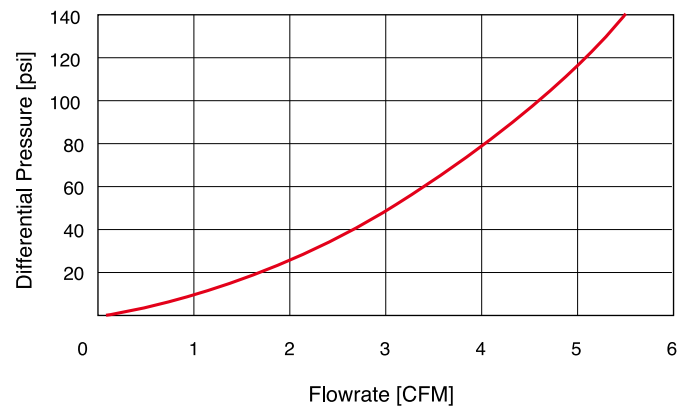

Pelmar Engineering Ltd.
Tel. (888) 754-6329, (416) 288-1736
E-mail: sales@pelmareng.com, www.pelmareng.com