

NOZZLE SCHEDULE			
MARK	QTY	SIZE / RATING	DESCRIPTION
N1	1	6"150# RFSO	INLET
N2	1	6"150# RFSO	OUTLET
N3	2	1/2" 3000# NPT	PRESSURE GAUGE
N4	1	1/2" 3000# NPT	VENT
N5	1	1" 3000# NPT	CLEAN DRAIN
N6	1	1/2" 3000# NPT	DIRTY DRAIN
VESSEL DESIGN CONDITIONS			
CODE: ASME SECTION VIII DIV. 1, 2015 EDITION			
M.A.W.P.: 150 PSI @ 250°F		M.D.M.T.: -20° F @ 150 PSI	
M.A.W.P.: FV PSI @ 250°F			
CORROSION ALLOWANCE: NONE		HYDROTEST PRESS: 195 PSI	
STAMP: U		SERVICE: NON LETHAL	
PWHT: N/A		RADIOGRAPHY: N/A	
MATERIAL: SS304		GASKET: BUNA-N	

**NOTES:**

1. VESSEL DRY WEIGHT: 640.01 LBS
2. VESSEL SHIPPING WEIGHT: 675 LBS
3. VESSEL FLOODED WEIGHT: 1150 LBS
4. VESSEL VOLUME: 8.5 FT<sup>3</sup>
5. VESSEL WILL HOUSE (QTY=6) SIZE 2 BASKETS.

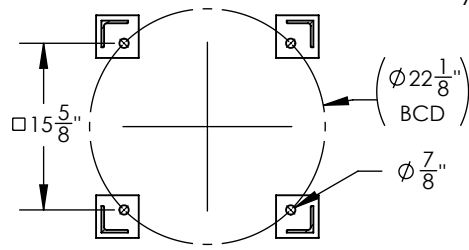
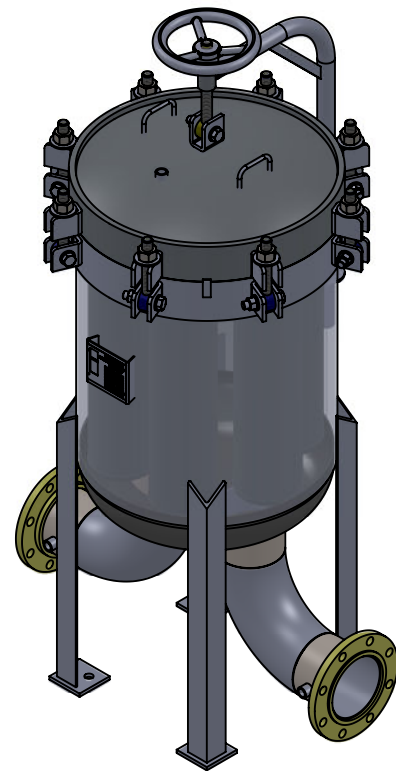
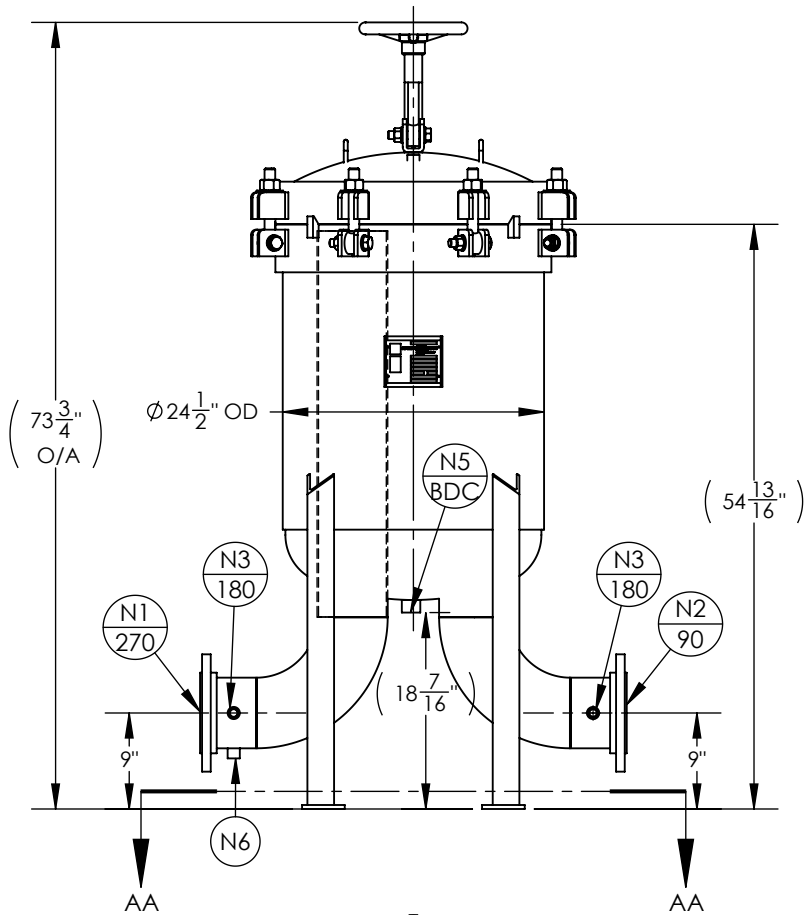

SECTION AA-AA  
SCALE 1 : 18

APPROVED WITH MARK-UPS  APPROVED

THIRD ANGLE PROJECTION  
TOLERANCES-UNLESS OTHERWISE NOTED  
DECIMAL .X = ±.1"  
.XX = ±.02"  
.XXX = ±.005"  
FRACTIONAL = ±1/8"  
ANGULAR = ± 1°  
MAX. MACHINED SURFACE FINISH 125/√

**FIL-TREK CORPORATION**  
55 Stafford Court  
Cambridge, Ontario  
N1T 1B3  
Canada  
Phone: (519) 623-7448  
Fax: (519) 623-8807  
Email: info@fil-trek.com  
Website: www.fil-trek.com

THIS DRAWING IS THE PROPERTY OF 'FIL-TREK CORPORATION' AND MUST NOT BE COPIED OR USED IN ANY WAY DETRIMENTAL TO THE CORPORATION

EQUIPMENT: BAG FILTER VESSEL (BMB SERIES)  
MODEL NO: S4BMB24-612-6F-150  
CUSTOMER:

PARENT: NEW DESIGN  
DRAWN: GB  
DATE: 22/06/2017  
SCALE: NTS  
SERIAL No.  
Part No. 002005-00033  
REV. No. 0