

NOZZLE SCHEDULE			
MARK	QTY	SIZE / RATING	DESCRIPTION
N1	1	3"150# RFSO	INLET
N2	1	3"150# RFSO	OUTLET
N3	2	1/2" 3000# NPT	PRESSURE GAUGE
N4	1	1/2" 3000# NPT	VENT
N5	1	2" 3000# NPT	CLEAN DRAIN
N6	1	1/2" 3000# NPT	DIRTY DRAIN
VESSEL DESIGN CONDITIONS			
CODE: ASME SECTION VIII DIV. 1, 2013 EDITION			
M.A.W.P.: 150 PSI @ 250°F		M.D.M.T.: -20° F @ 150 PSI	
M.A.E.P.: 15 PSI @ 250°F			
CORROSION ALLOWANCE: NONE		HYDROTEST PRESS: 195 PSI	
STAMP: 'U' CRN, BC, AB, SK		SERVICE: NON LETHAL	
PWHT: N/A		RADIOGRAPHY: N/A	
MATERIAL: CS		GASKET: BUNA-N	

- NOTES:
- VESSEL WILL HOUSE (QTY=3) SIZE 2 BASKETS.
 - CRN: K6777.13 /T6481.2
 - DRY WEIGHT: 356.97 LBS
 - FLOODED WEIGHT: 670 LBS
 - SHIPPING WEIGHT: 420 LBS
 - VESSEL VOLUME: 4.9 CU FT

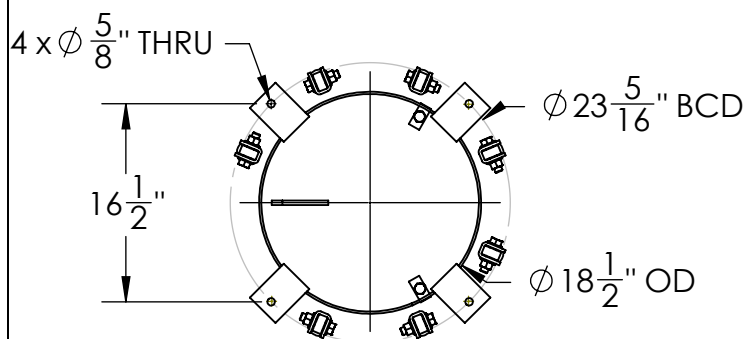
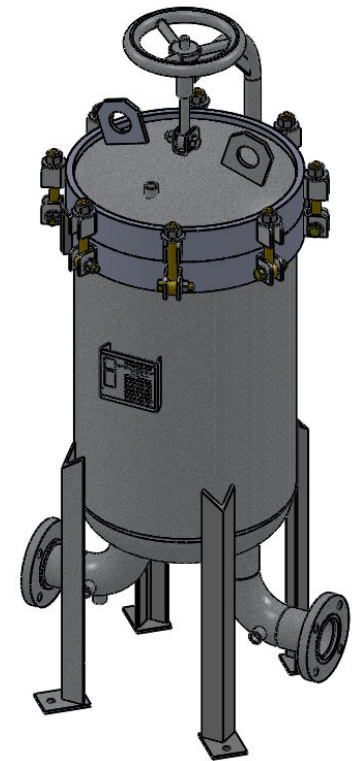
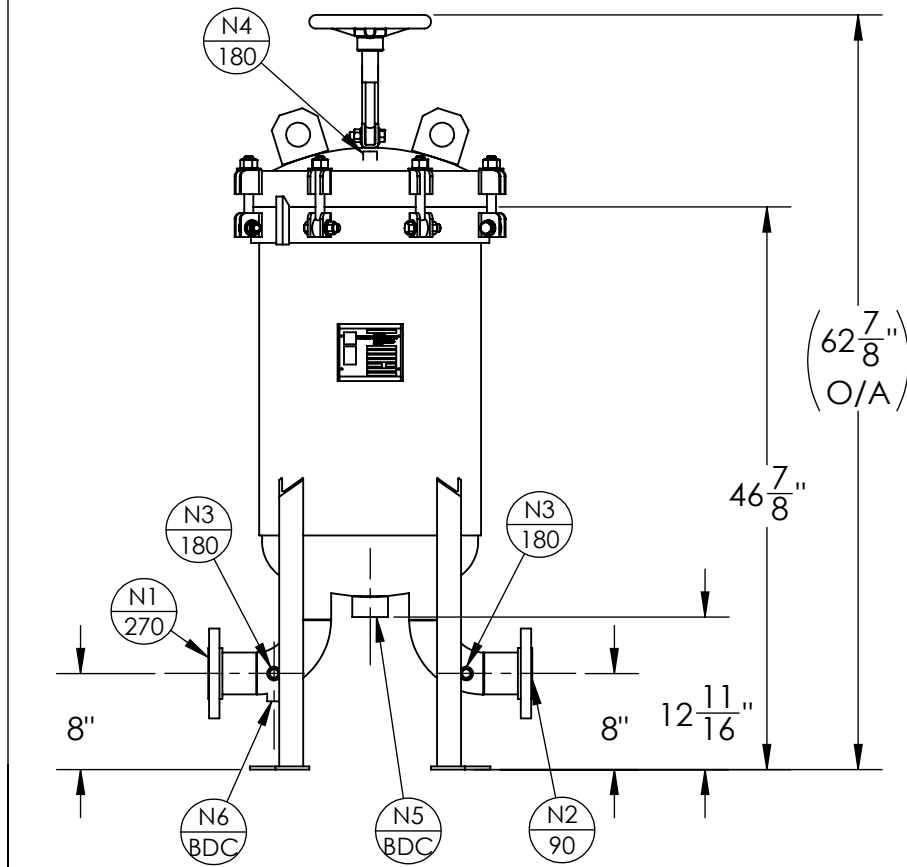

<p>THIRD ANGLE PROJECTION</p> <p>TOLERANCES-UNLESS OTHERWISE NOTED</p> <p>DECIMAL .X = ±.1" .XX = ±.02" .XXX = ±.005"</p> <p>FRACTIONAL = ± 1/8"</p> <p>ANGULAR = ± 1°</p> <p>MAX. MACHINED SURFACE FINISH 125/√</p>	<p>FIL-TREK CORPORATION</p> <p>55 Stafford Court Cambridge, Ontario N1T 1B3 Canada</p> <p>Phone: (519) 623-7448 Fax: (519) 623-8807 Email: info@fil-trek.com Website: www.fil-trek.com</p>				
	<p>THIS DRAWING IS THE PROPERTY OF 'FIL-TREK CORPORATION' AND MUST NOT BE COPIED OR USED IN ANY WAY DETRIMENTAL TO THE CORPORATION</p> <p>EQUIPMENT: BAG FILTER VESSEL (BMB SERIES)</p> <p>MODEL NO: BMB18-312-3F-150</p> <p>CUSTOMER: STOCK</p>				
<p>PARENT: V6886</p>	<p>DRAWN: TS</p>	<p>DATE: 12/22/2015</p>	<p>SERIAL No. V8543</p>	<p>Part No. 002005-00008</p>	<p>REV. No. 0</p>
	<p>CHK'D: CR</p>	<p>SCALE: NTS</p>	<p>DWG. No. R001283-1</p>		