

NOZZLE SCHEDULE			
MARK	QTY	SIZE / RATING	DESCRIPTION
N1	1	4" 150# RFSO	INLET
N2	1	4" 150# RFSO	OUTLET
N3	2	1/2" 3000# NPT	PRESSURE GAUGE
N4	1	1/2" 3000# NPT	VENT
N5	1	2" 3000# NPT	CLEAN DRAIN
N6	1	1/2" 3000# NPT	DIRTY DRAIN

VESSEL DESIGN CONDITIONS			
CODE: ASME SECTION VIII DIV. 1, 2015 EDITION			
M.A.W.P.: 150 PSI @ 250°F		M.D.M.T.: -20° F @ 150 PSI	
M.A.E.P.: 15 PSI @ 250°F			
CORROSION ALLOWANCE: NONE		HYDROTEST PRESS: 195 PSI	
STAMP: U		SERVICE: NON LETHAL	
PWHT: NONE		RADIOGRAPHY: NONE	
MATERIAL: SS304		GASKET: BUNA-N	

- NOTES:
- VESSEL WILL HOUSE (QTY=4) SIZE 2 BASKETS.
  - DRY WEIGHT: 345.66 LBS
  - FLOODED WEIGHT: 760 LBS
  - SHIPPING WEIGHT: 410 LBS
  - VESSEL VOLUME: 6.3 FT<sup>3</sup>

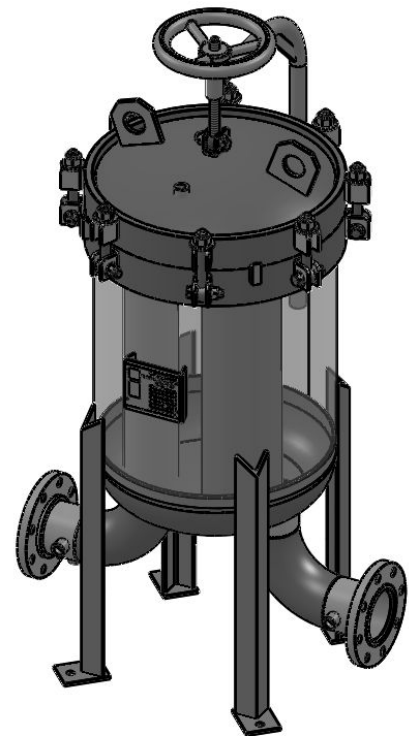

APPROVED WITH MARK-UPS  APPROVED

<p>THIRD ANGLE PROJECTION</p> <p>TOLERANCES-UNLESS OTHERWISE NOTED</p> <p>DECIMAL .X = ±.1" .XX = ±.02" .XXX = ±.005"</p> <p>FRACTIONAL = ±1/8"</p> <p>ANGULAR = ± 1°</p> <p>MAX. MACHINED SURFACE FINISH 125/√</p>	<p><b>FIL-TREK CORPORATION</b></p> <p>55 Stafford Court Cambridge, Ontario N1T 1B3 Canada</p> <p>Phone: (519) 623-7448 Fax: (519) 623-8807 Email: info@fil-trek.com Website: www.fil-trek.com</p>				
	<p>THIS DRAWING IS THE PROPERTY OF 'FIL-TREK CORPORATION' AND MUST NOT BE COPIED OR USED IN ANY WAY DETRIMENTAL TO THE CORPORATION</p> <p>EQUIPMENT: BMB SERIES (BAG FILTER VESSEL)</p> <p>MODEL NO: S4BMB20-412-4F-150</p> <p>CUSTOMER:</p>				
PARENT:	DRAWN: JN	DATE: 24/05/2017	SERIAL No.	Part No. 002005-00029	REV. No. 0
CHK'D:	SCALE: NTS				