

NOZZLE SCHEDULE			
MARK	QTY	SIZE / RATING	DESCRIPTION
N1	1	3" 150# RFSO	INLET
N2	1	3" 150# RFSO	OUTLET
N3	2	1/2" 3000# NPT	PRESSURE GAUGE
N4	1	1/2" 3000# NPT	VENT
N5	1	2" 3000# NPT	CLEAN DRAIN
N6	1	1/2" 3000# NPT	DIRTY DRAIN
VESSEL DESIGN CONDITIONS			
CODE: ASME SECTION VIII DIV. 1, 2015 EDITION			
M.A.W.P.: 150 PSI @ 250°F		M.D.M.T.: -20° F @ 150 PSI	
M.A.E.P.: 15 PSI @ 250°F			
CORROSION ALLOWANCE: NONE		HYDROTEST PRESS: 195 PSI	
STAMP: U		SERVICE: NONE	
PWHT: N/A		RADIOGRAPHY: N/A	
MATERIAL: CS		GASKET: BUNA	

NOTES:

1. VESSEL WILL HOUSE (QTY=2) STAINLESS STEEL SIZE 2 BASKETS 1/8" ON 3/16" CENTERS.
2. DRY WEIGHT: 344.30 LBS
3. FLOODED WEIGHT: 570 LBS
4. SHIPPING WEIGHT: 450 LBS
5. VESSEL VOLUME: 3.5 FT³

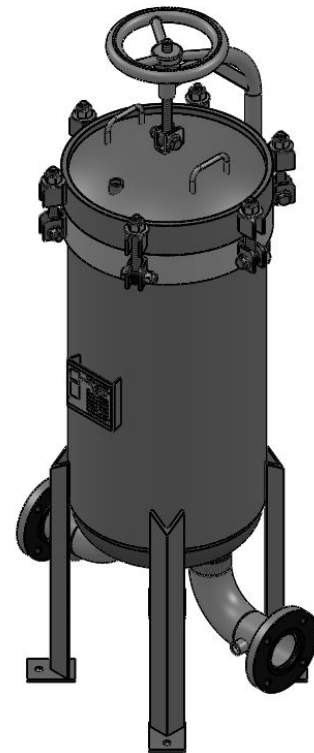

APPROVED WITH MARK-UPS APPROVED



THIRD ANGLE PROJECTION
TOLERANCES-UNLESS OTHERWISE NOTED
DECIMAL .X = ±.1"
.XX = ±.02"
.XXX = ±.005"
FRACTIONAL = ±1/8"
ANGULAR = ± 1°
MAX. MACHINED SURFACE FINISH 125/√



FIL-TREK CORPORATION

55 Stafford Court
Cambridge, Ontario
N1T 1B3
Canada

Phone: (519) 623-7448
Fax: (519) 623-8807
Email: info@fil-trek.com
Website: www.fil-trek.com

THIS DRAWING IS THE PROPERTY OF 'FIL-TREK CORPORATION' AND MUST NOT BE COPIED OR USED IN ANY WAY DETRIMENTAL TO THE CORPORATION

EQUIPMENT: BAG FILTER VESSEL (BMB SERIES)

MODEL NO: BMB16-212-3F-150

CUSTOMER:

PARENT: NEW DESIGN	DRAWN: JN	DATE: 02/05/2017	SERIAL No.	Part No.	REV. No. 0
	CHK'D:	SCALE: NTS			