

NOZZLE SCHEDULE			
MARK	QTY	SIZE / RATING	DESCRIPTION
N1	1	6"150# RFSO	INLET
N2	1	6"150# RFSO	OUTLET
N3	2	1/2" 3000# NPT	PRESSURE GAUGE
N4	1	1/2" 3000# NPT	VENT
N5	1	2" 3000# NPT	CLEAN DRAIN
N6	1	1/2" 3000# NPT	DIRTY DRAIN
VESSEL DESIGN CONDITIONS			
CODE: ASME SECTION VIII DIV. 1, 2015 EDITION			
M.A.W.P.: 150 PSI @ 250°F		M.D.M.T.: -20° F @ 150 PSI	
M.A.W.P.: FV PSI @ 250°F			
CORROSION ALLOWANCE: NONE		HYDROTEST PRESS: 195 PSI	
STAMP: "U"		SERVICE: NON LETHAL	
PWHT: N/A		RADIOGRAPHY: N/A	
MATERIAL: CS		GASKET: BUNA-N	

NOTES:

1. VESSEL DRY WEIGHT: 636.26 LBS
2. VESSEL SHIPPING WIEGHT: 800 LBS
3. VESSEL FLOODED WEIGHT: 1150 LBS
4. VESSEL VOLUME: 7.85 FT<sup>3</sup>
5. VESSEL WILL HOUSE (QTY=6) SIZE 2 BASKETS.

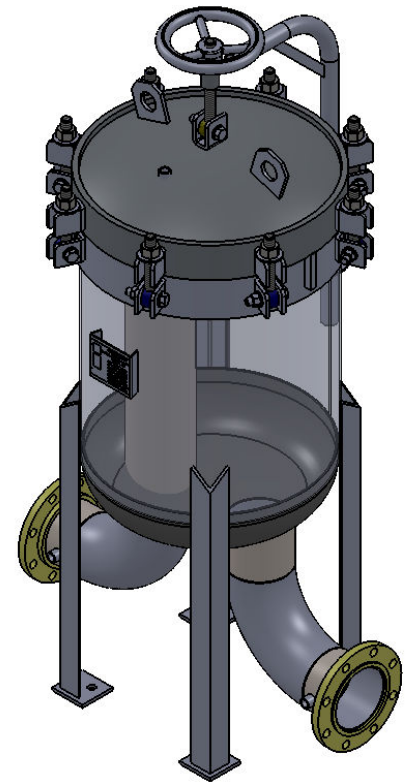

<p>THIRD ANGLE PROJECTION</p> <p>TOLERANCES-UNLESS OTHERWISE NOTED</p> <p>DECIMAL .X = ±.1" .XX = ±.02" .XXX = ±.005"</p> <p>FRACTIONAL = ±1/8"</p> <p>ANGULAR = ± 1°</p> <p>MAX. MACHINED SURFACE FINISH 125/√</p>	<p><b>FIL-TREK CORPORATION</b></p> <p>55 Stafford Court Cambridge, Ontario N1T 1B3 Canada</p> <p>Phone: (519) 623-7448 Fax: (519) 623-8807 Email: info@fil-trek.com Website: www.fil-trek.com</p>	
	<p>THIS DRAWING IS THE PROPERTY OF 'FIL-TREK CORPORATION' AND MUST NOT BE COPIED OR USED IN ANY WAY DETRIMENTAL TO THE CORPORATION</p> <p>EQUIPMENT: BAG FILTER VESSEL (BMB SERIES)</p> <p>MODEL NO: BMB24-612-6F-150</p> <p>CUSTOMER:</p>	
<p>PARENT: NEW DESIGN</p> <p>CHK'D:</p>	<p>DRAWN: VD</p> <p>DATE: 5/2/2017</p> <p>SCALE: NTS</p>	<p>SERIAL No.</p> <p>Part No. 002005-00013</p>
		<p>REV. No. 0</p>