

SECTION L-L
SCALE 1 : 22

NOZZLE SCHEDULE			
MARK	QTY	SIZE / RATING	DESCRIPTION
N1	1	8" 150# RFSO	INLET
N2	1	8" 150# RFSO	OUTLET
N3	2	1/2" 3000# NPT	PRESSURE GAUGE
N4	1	1/2" 3000# NPT	VENT
N5	1	2" 3000# NPT	CLEAN DRAIN
N6	1	1/2" 3000# NPT	DIRTY DRAIN
VESSEL DESIGN CONDITIONS			
CODE: ASME SECTION VIII DIV. 1, 2015 EDITION			
M.A.W.P.: 150 PSI @ 250°F		M.D.M.T.: -20° F @ 150 PSI	
M.A.E.P.: 15 PSI @ 250°F			
CORROSION ALLOWANCE: NONE		HYDROTEST PRESS: 195 PSI	
STAMP: UM		SERVICE: NON LETHAL	
PWHT: N/A		RADIOGRAPHY: N/A	
MATERIAL: SS304		GASKET: BUNA	

- NOTES:
1. VESSEL WILL HOUSE (QTY=12) DOUBLE LENGTH BASKETS.
 2. DRY WEIGHT: 1335.93 LBS.
 3. FLOODED WEIGHT: 2325 LBS.
 4. SHIPPING WEIGHT: 1600 LBS.
 5. VESSEL VOLUME: 15.75 FT³

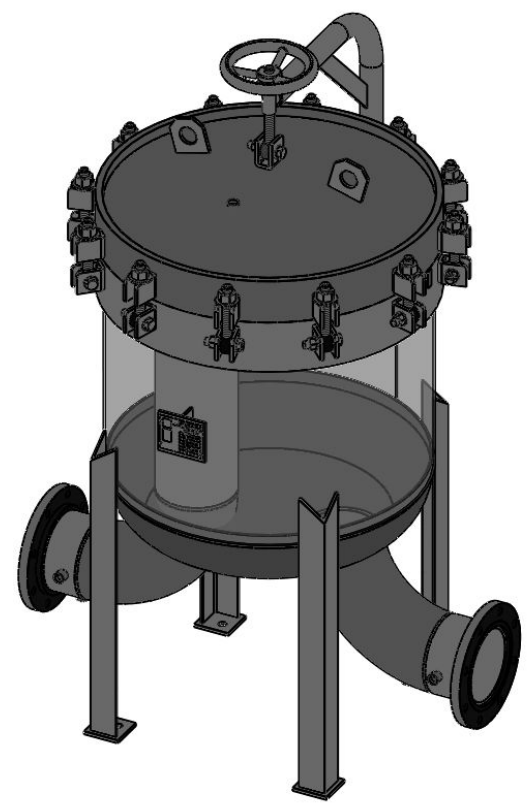

APPROVED WITH MARK-UPS APPROVED

<p>THIRD ANGLE PROJECTION</p>	<p>FIL-TREK CORPORATION</p> <p>55 Stafford Court Cambridge, Ontario N1T 1B3 Canada</p> <p>Phone: (519) 623-7448 Fax: (519) 623-8807 Email: info@fil-trek.com Website: www.fil-trek.com</p>		
	<p>THIS DRAWING IS THE PROPERTY OF 'FIL-TREK CORPORATION' AND MUST NOT BE COPIED OR USED IN ANY WAY DETRIMENTAL TO THE CORPORATION</p>		
<p>EQUIPMENT: BAG FILTER VESSEL (BMB SERIES)</p>		<p>MODEL NO: S4BMB34-1212-8F-150</p>	
<p>CUSTOMER:</p>		<p>DRAWN: JN DATE: 09/05/2017 SERIAL No. Part No. 002005-00028</p>	
<p>PARENT: NEW DESIGN</p>		<p>CHK'D: SCALE: NTS</p>	
		<p>REV. No. 1</p>	