

TAGLINE Filters

Irrigation high quality all plastic filters for flowrates up to 50 m³/h (220 gpm)



flowrates

**up to 50 m³/h
220 gpm**

filtration degrees

500-80 micron

diameters

**20mm - 75mm
¾" - 3"**

maximum operating
pressure

**8 bar
116 psi**

features:

- Easy maintenance: no tools required for extracting the elements from the filter housing for rinsing
- High quality, excellent mechanical strength and corrosion resistance
- Low pressure loss
- Interchangeable filter elements for wide range of flowrates, various filtration degrees and irrigation applications
- Screen cylinders or Disc elements

Amiad TAGLINE Filter Series

General

With their Screen and Disc elements Amiad TAGLINE filters are made for wide range of irrigation applications. The TAGLINE filters are available in various filtration degrees to cover the needs of modern irrigation systems. TAGLINE filters are made from high quality engineered plastic materials providing excellent mechanical strength, durability and ease of installation.

Amiad's TAGLINE filters are easy to maintain; no tools are needed for extracting the filter element from the filter housing for rinsing.

Filter Elements

Amiad supplies a variety of filter elements for its plastic filters that cover a wide range of flowrates, filtration degrees and applications.

Screen Elements: [1]

These screen elements are constructed of molded plastic ribs that support a stainless steel weavewire or weaved polyester screen for filtration degrees of 500 to 80 micron.

Perforated Stainless Steel Elements: [2]

Suitable for coarse filtration (straining) between 3,500 and 500 micron.

Disc Elements: [3]

The disc elements are designed for effective removal of organic substances. The elements are constructed using engineered plastic discs that are stacked onto a telescopic core. The discs are grooved on both sides and intersect to form the filtration element when compressed. Filtration degrees 200 to 100 micron.

The effective filtration area is comprised of both the outside surface and the channels formed by the intersecting grooves. Suspended organic particles adhere to the grooved surface adding depth to the filtration process.

Cleaning the disc element is made simple by the unique design of the telescopic core which allows the discs to separate during the cleaning process while maintaining perfect sealing when the element is in the filter housing.



Filtration Degrees Available

The following table lists the various filter elements of Amiad's TAGLINE filters and the optional filtration degrees for each filter element. For ease of operation and maintenance the various filtration degrees are color coded. Please consult your dealer for the most suitable filter element for your application requirements.

Color	Black	Yellow	Red	White	Blue	Blue
Micron	80	100	130	200	300	500
Mesh	200	155	120	75	50	30
¾", 1", 1½"	▲	■ ▲	■ ▲	▲	■ ▲	▲
2", 2" S, 3"	▲	▲ ●	▲ ●	▲ ●	▲	▲

■ Polyester Screen ▲ St.st. Weaveire Screen ● Disc Element

Technical Specifications

Filter Type	3"	2" - S	2"
General Data			
Maximum flowrate*	50 m³/h (220 gpm)	25 m³/h (110 gpm)	
Inlet/Outlet diameter	80 mm (3")	50 mm (2")	
Filtration degrees	500, 300, 200, 130, 100, 80 micron		
Max. working pressure	8 bar (116 psi)		
Max. working temperature	60°C (140°F)		
Weight [empty]	Screen = 4.5 kg (9.9 lbs) Discs = 5.7 kg (12.5 lbs)	Screen = 4.2 kg (9.2 lbs) Discs = 5.4 kg (11.9 lbs)	Screen = 4.5 kg (9.9 lbs) Discs = 5.7 kg (12.5 lbs)

* Consult Amiad for optimum flow depending on filtration degree & water quality.

Engineering Data

Filter Element Data		
Filtration area	1200 cm² (186 in²)	800 cm² (124 in²)
Filter element types	Polyester screen, weavewire screen, st. st. screen, disc element	

Construction Materials*	
Filter housing	Polypropylene + Glass Fibers
Filter lid	Polypropylene + Glass Fibers
Tightening nut	Polypropylene + Glass Fibers
Housing seal	NBR
Screen	Construction = Polypropylene Mesh = St. st. or Polyester Seals = NBR
Discs	Construction = Polypropylene Grooved discs = Polypropylene Seals = NBR

* Amiad offers a variety of construction materials. Consult us for specifications.

Technical Specifications

Filter Type	1½"	1"	¾"
-------------	-----	----	----

General Data			
Maximum flow rate*	15 m³/h (66 gpm)	5 m³/h (22 gpm)	3 m³/h (13.2 gpm)
Inlet/Outlet diameter	40 mm (1½")	25 mm (1")	
Filtration degrees	500, 300, 200, 130, 100, 80 micron		
Max. working pressure	8 bar (116 psi)		
Max. working temperature	60°C (140°F)		
Working temperature range	60°C (140°F)		
Weight [empty]	1.0 kg (2.2 lbs)	0.17 kg (0.37 lbs)	0.16 kg (0.35 lbs)

* Consult Amiad for optimum flow depending on filtration degree & water quality.

Engineering Data

Filter Element Data			
Filtration area	460 cm² (71 in²)	200 cm² (31 in²)	140 cm² (22 in²)
Filter Element types	Polyester, st. st screen, weavewire screen		

Construction Materials*	
Filter housing	Polypropylene
Filter Lid	Polypropylene
Housing seal	NBR
Screen	Construction = Polypropylene Mesh = St. st. or Polyester Seals = NBR

* Amiad offers a variety of construction materials. Consult us for specifications.

3"

Dimentional Drawing

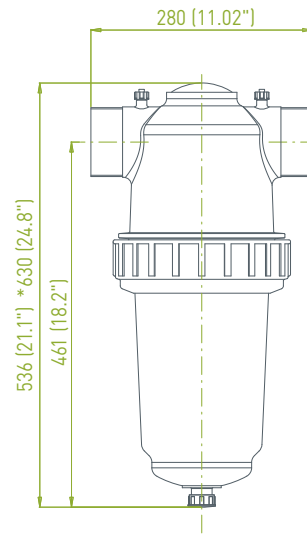

2"-S

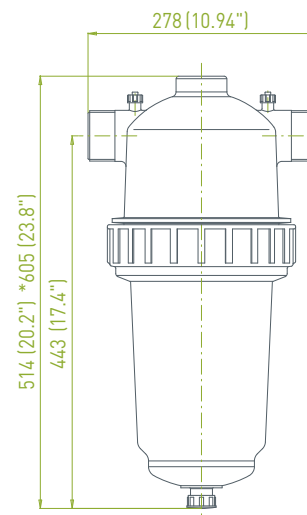

2"

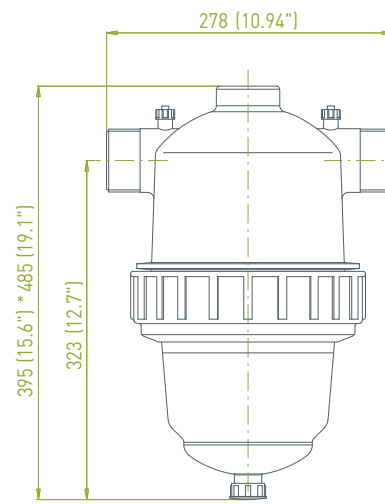

Dim: mm (inch)

*Approx. length required for maintenance

Typical Installation Drawing

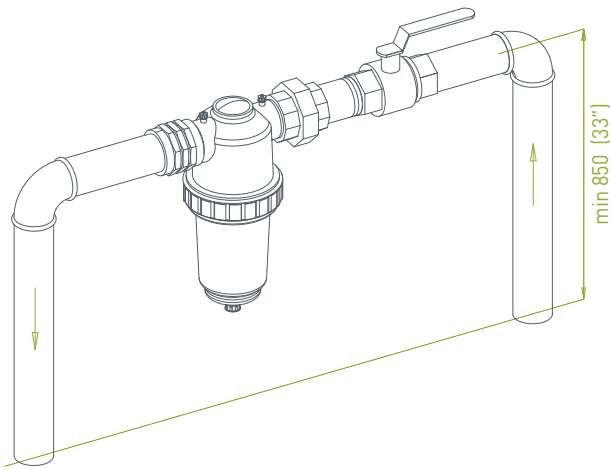

Pressure Loss Graph in clean water

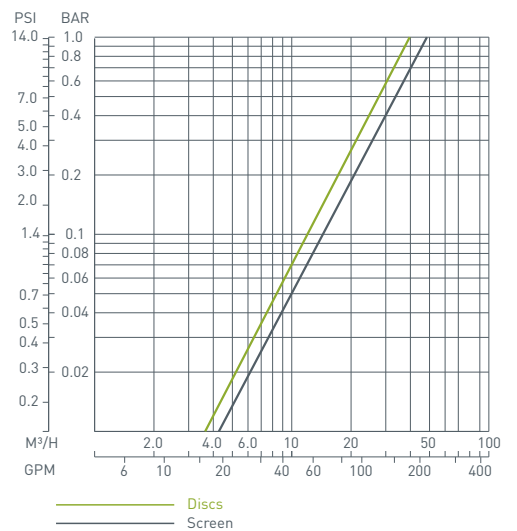
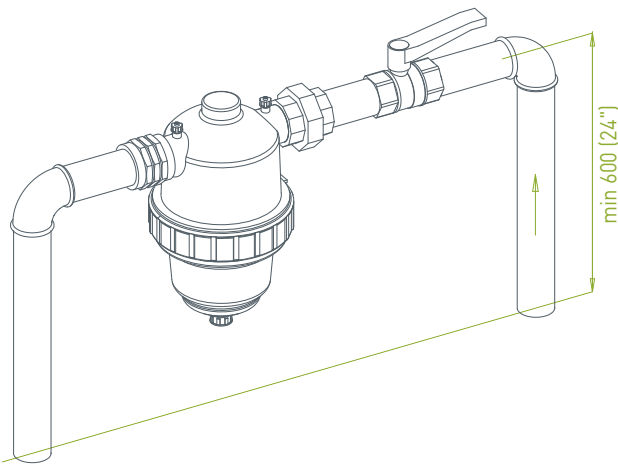
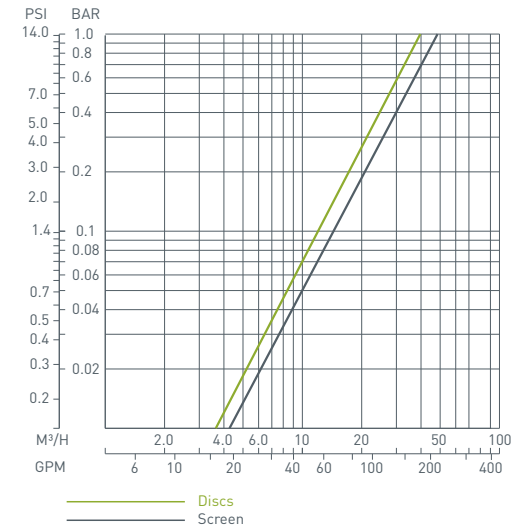
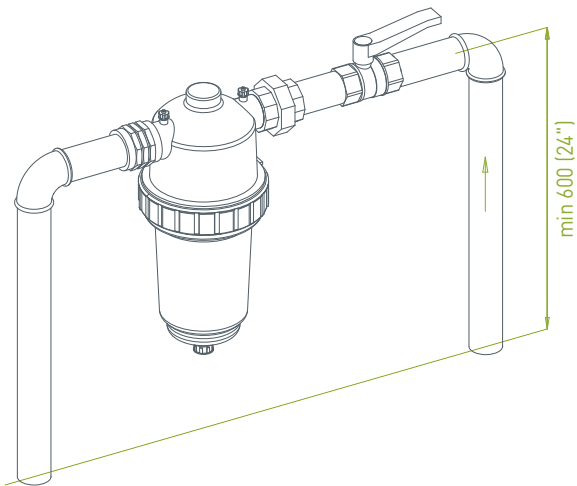
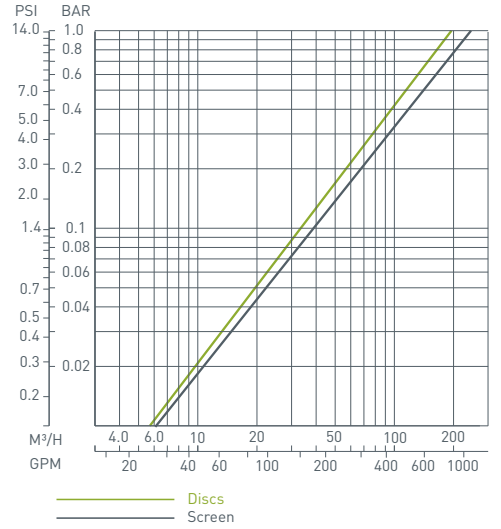

Dim: mm (inch)

1½"

Dimensional Drawing

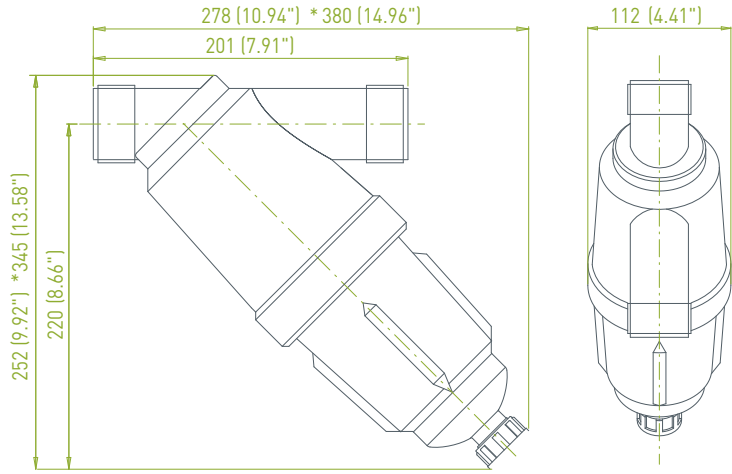

1"

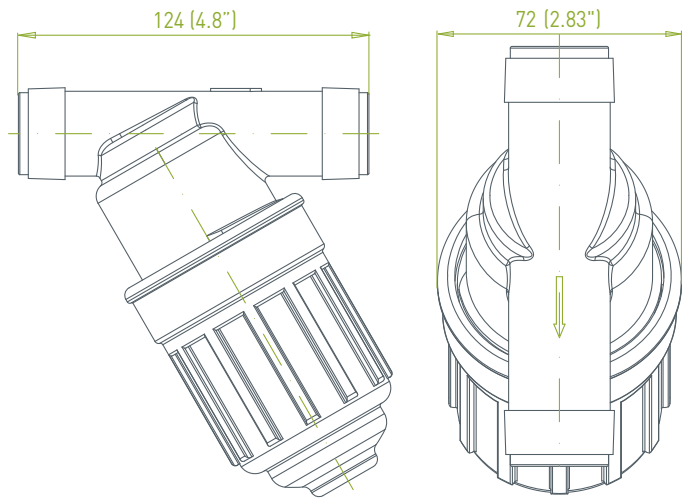

¾"

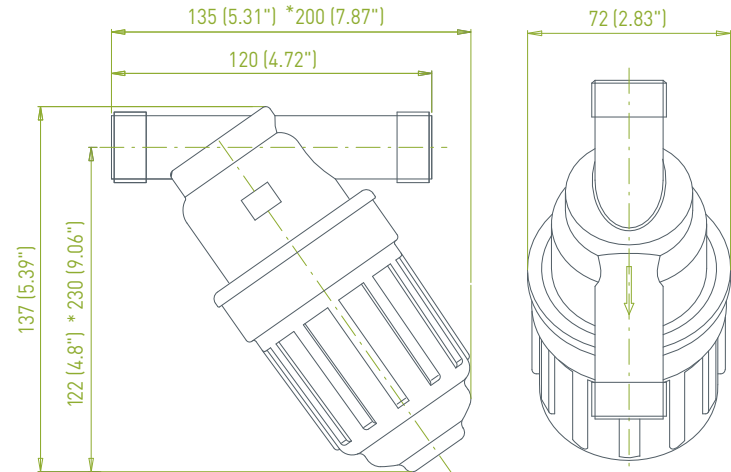

Dim: mm (inch)

*Approx. length required for maintenance

Typical Installation Drawing

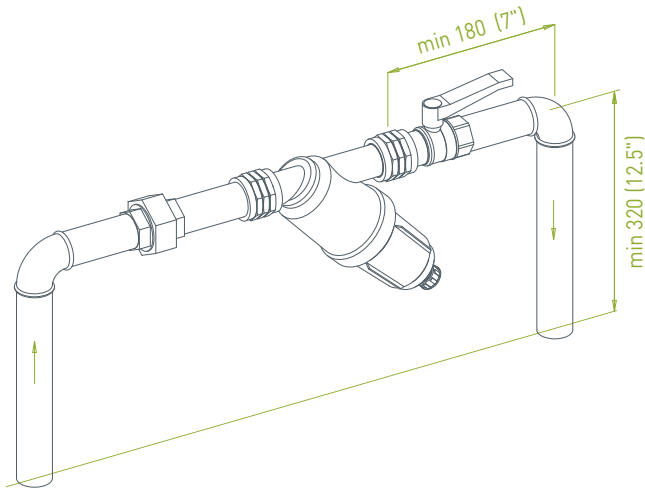

Pressure Loss Graph in clean water

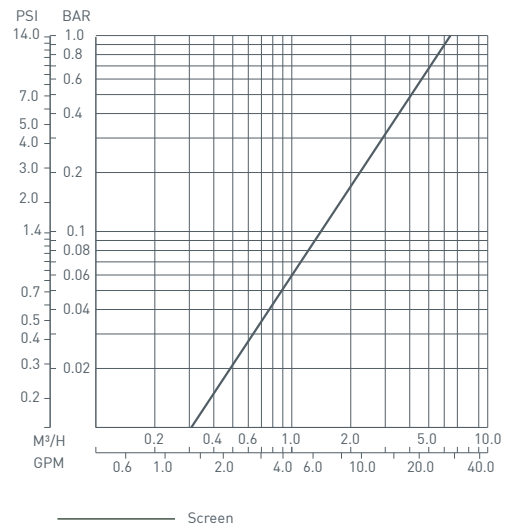
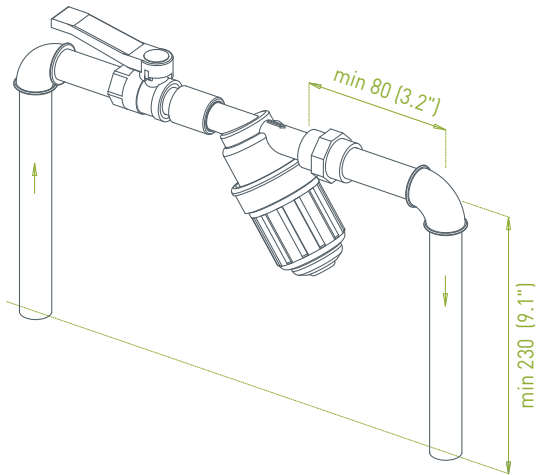
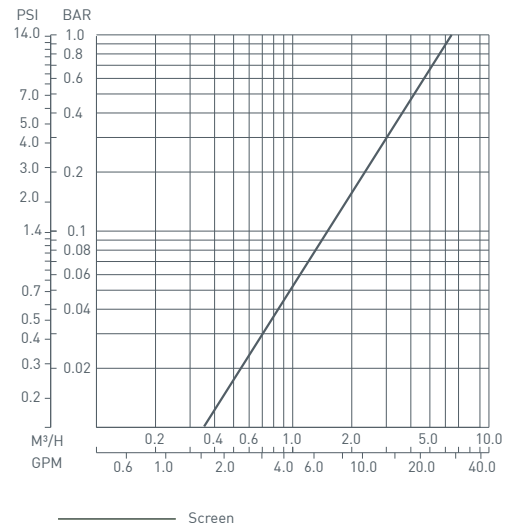
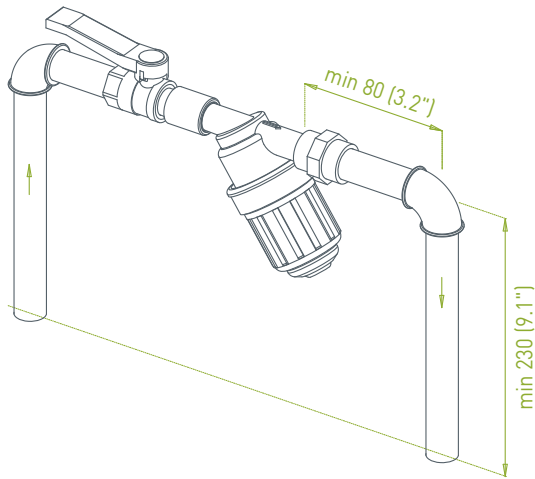
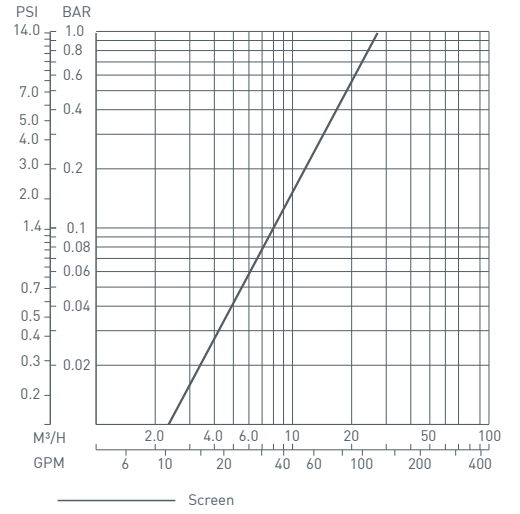

Dim: mm (inch)

Headquarters

Amiad Water Systems Ltd.
Web: www.amiad.com | E-mail: info@amiad.com

The Americas



USA
Amiad USA Inc.
Web: us.amiad.com | E-mail: infousa@amiad.com

Mexico
Amiad México SA DE CV,
Web: es.amid.com
Irrigation office: E-mail: infomexico-irr@amiad.com

Asia



India
Amiad Filtration India Pvt Limited
Web: www.amiad.com | E-mail: info-india@amiad.com

China
Amiad China (Yixing Taixing Environtec Co., Ltd.)
Web: www.amiad.com.cn | E-mail: infochina@amiad.com

South-East Asia
Filtration & Control Systems Pte. Ltd.
E-mail: info-singapore@amiad.com

Australia



Amiad Australia Pty Ltd.
Web: au.amiad.com | E-mail: sales@amiad.com

Europe



Amiad Water Systems Europe SAS
Web: fr.amiad.com
E-mail: irrigation-europe@amiad.com

German branch office
Web: de.amiad.com
E-mail: info@amiad.com

United Kingdom
Amiad Water Systems UK Limited
E-mail: info-uk@amiad.com



www.amiad.com

910101-000386/04.2021

Copyright © 2019 Amiad Water Systems Ltd. All rights reserved. The contents of this catalogue including without limitation all information and materials, images, illustrations, designs, icons, photographs, graphical presentations, designs, literary works, data, drawings, slogans, phrases, names, trademarks, titles and any other such materials that appear in this catalogue (collectively, the "Contents") are the sole property of Amiad Water Systems Ltd. ("Amiad"). Amiad has sole and exclusive right, title and interest in the Contents, including any intellectual property rights, whether registered or not, and all know-how contained or embodied therein. You may not reproduce, publish, transmit, distribute, display, modify, create derivative works from, sell or participate in any sale of, or exploit in any way, in whole or in part, any of the Contents or the catalogue. Any use of the catalogue or the Contents, other than for personal use, requires the advanced written permission of Amiad.