

4

3

2

1

IQ1700B SPEC DRAWING

IQ1700B
 COOLING CAPACITY: 1700BTUH (499W) @ 131°F (55°C)
 MAXIMUM AMPS: 3.50 (420W) @120V/60HZ
 MAXIMUM AMPS: 1.50 (345W) @230V/60HZ
 MAXIMUM OPERATING TEMP: 131°F (55°C)
 MINIMUM OPERATING TEMP: -40°F (-40°C)
 DIMENSIONS: 20.933" (532MM) H x 14.055" (357MM) W x 4.390" (111MM) D
 WEIGHT: 28.66 LBS (13KG)
 EVAP. OUTLET ≈ 175 CFM
 COND. OUTLET ≈ 250 CFM
 SOUND LEVEL @5FT FROM UNIT @ A HT. OF 3FT = 68 dBA
 SOUND LEVEL @2FT FROM UNIT @ A HT. OF 5FT = 71 dBA
 CONDENSER INLET MIN. CLEARANCE 1.80"

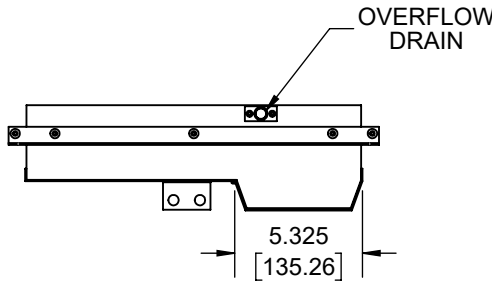
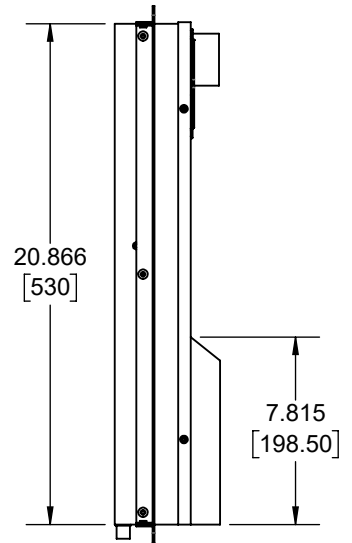
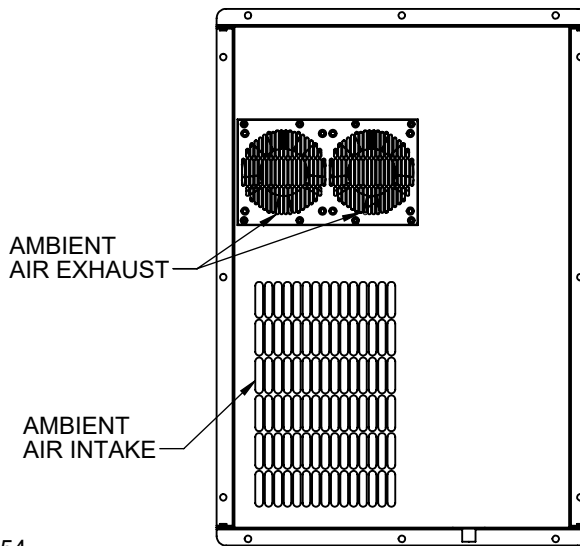
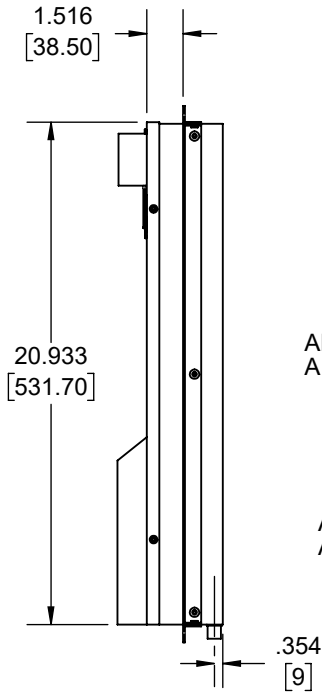
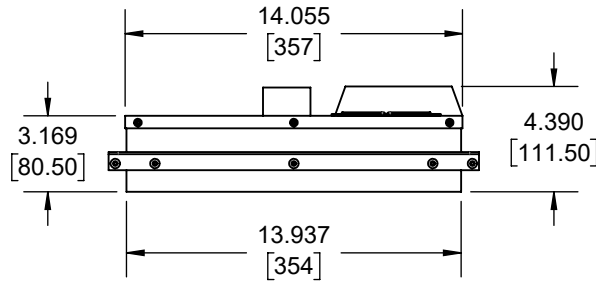

D	ADDED CFM, dBA, AND CLEARANCE INFO	RCC	4/26/2018			1351
C	ADDED WATTAGE INFO	RCC	1/4/2018			
B	MOVED CONTROLLER TO FRONT	RCC	11/20/2017			
A	INITIAL RELEASE	ART	8/31/2015			1229
REV	REVISION	CHG	DATE	APP	DATE	CN#

PART NUMBER	N/A
USED ON	IQ1700B
MATERIAL	N/A
EST WT:	lbs
DRAWN BY	ART
DATE	3/18/2015
SCALE	1:8

UNLESS OTHERWISE SPECIFIED TOLERANCES	
.X	±.060
.XX	±.030
.XXX	±.015
FRACTIONAL	±1/4
ANGULAR	±1/2°
SURFACE FINISH	63
DO NOT SCALE DRAWING DIMENSIONS ARE INCHES	

ICE QUBE, INC.
 THIS IS A PROPRIETARY DOCUMENT. DO NOT REPRODUCE OR DISCLOSE WITHOUT THE EXPRESS WRITTEN PERMISSION OF ICE QUBE, INC.
 DESCRIPTION
SPEC DRAWING, IQ1700B
 DRAWING NUMBER
IQ350397
 REV
D

E

D

C

B

A

E

D

C

B

A

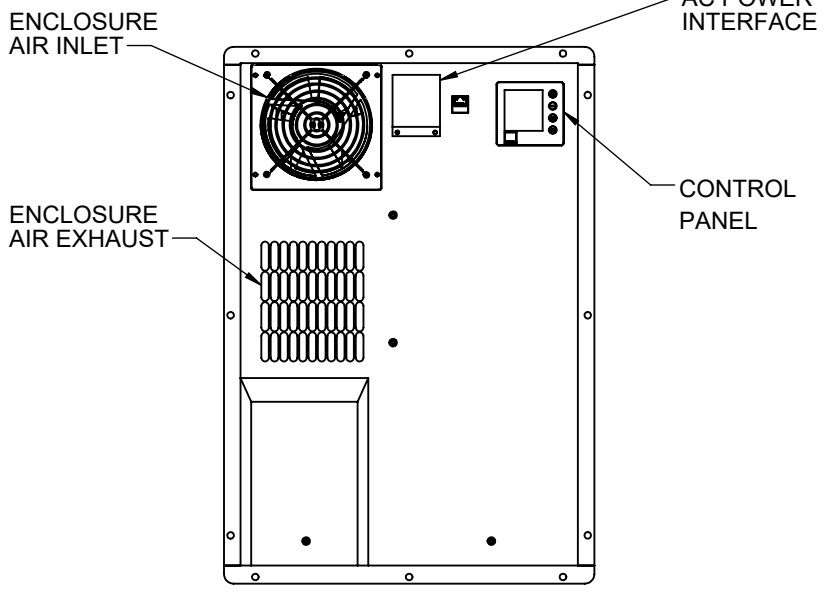

CUTOUT TEMPLATE

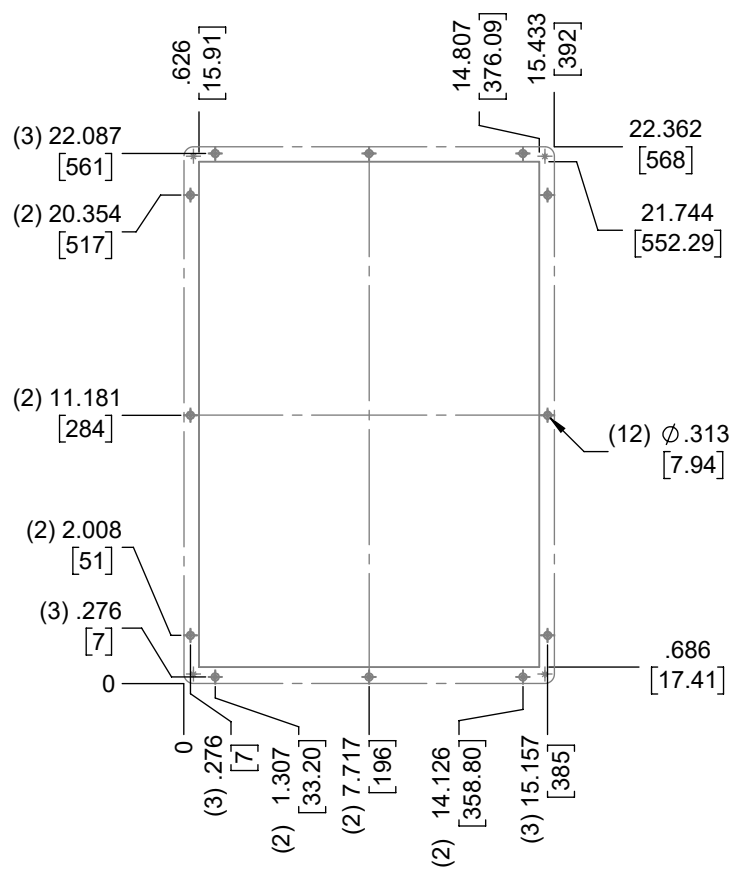

GASKET VIEW

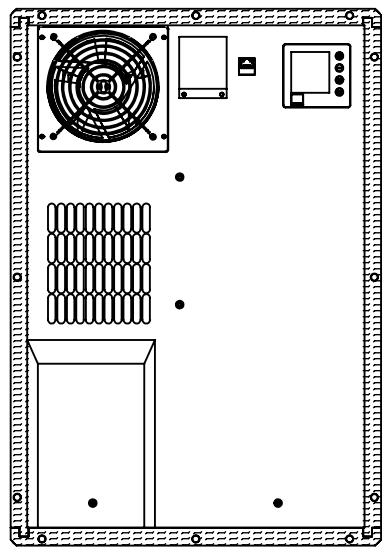

IMPORTANT
 GASKET MUST BE APPLIED AS SHOWN
 FOR PROPER OPERATION AND TO
 MAINTAIN NEMA INTEGRITY

PART NUMBER <i>N/A</i>		USED ON <i>IQ1700B</i>	
MATERIAL <i>N/A</i>			
EST WT: DRAWN BY <i>ART</i>	lbs	DATE <i>3/18/2015</i>	SCALE <i>1:8</i>

UNLESS OTHERWISE SPECIFIED TOLERANCES

.X ±.060
 .XX ±.030
 .XXX ±.015

FRACTIONAL ±1/4
 ANGULAR ±1/2°

SURFACE FINISH $\sqrt{63}$

DO NOT SCALE DRAWING DIMENSIONS ARE INCHES

ICE QUBE, INC.

THIS IS A PROPRIETARY DOCUMENT. DO NOT REPRODUCE OR DISCLOSE WITHOUT THE EXPRESS WRITTEN PERMISSION OF ICE QUBE, INC.

DESCRIPTION
SPEC DRAWING, IQ1700B

DRAWING NUMBER
IQ350397

REV
D