

IQ10000EVZ2 CLASS I ZONE 2 AEx / Ex ZONE 2 ATEX / IECEx CERTIFIED

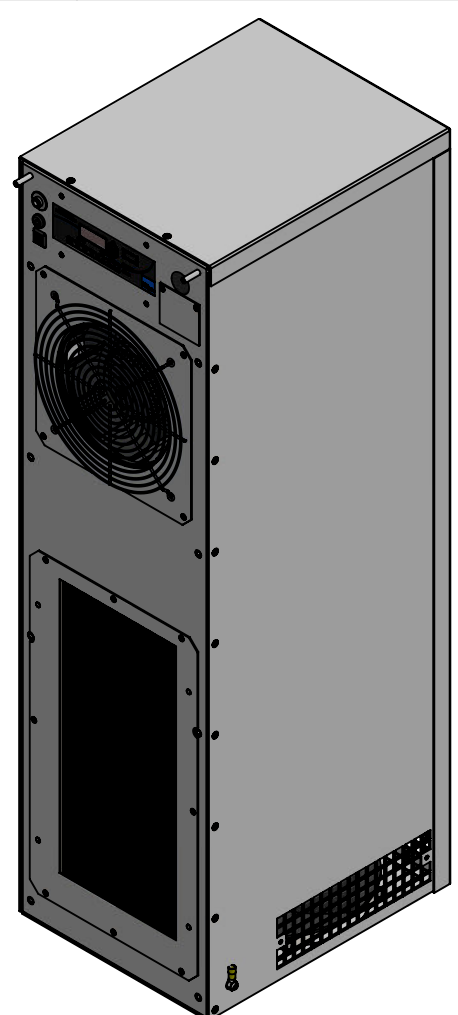
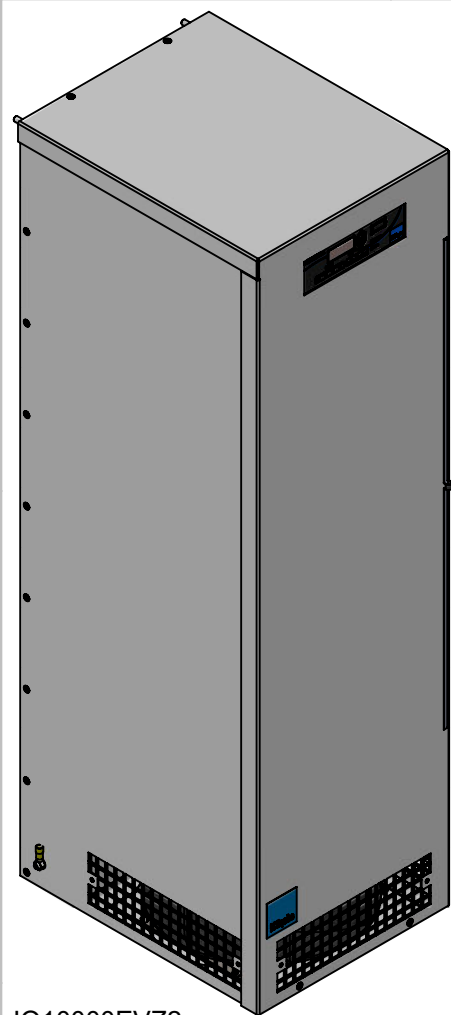

STANDARD
CONTROLLER
LOCATION

AMBIENT INTAKE FILTER

(2) PEM, STUD, 1/4"-20, 1"LG

OPTIONAL
CONTROLLER
LOCATION

Ø 6.625
[168.28]
WITH GUARD

ENCLOSURE
INTAKE

ENCLOSURE
EXHAUST

EXTERNAL GROUND
Ø6MM, 12MM LG STUD
WITH RING TERMINAL

AMBIENT EXHAUST

(8) PEM, NUT, 1/4"-20, .054"

DRAIN TUBE .375" [9.53] O.D.

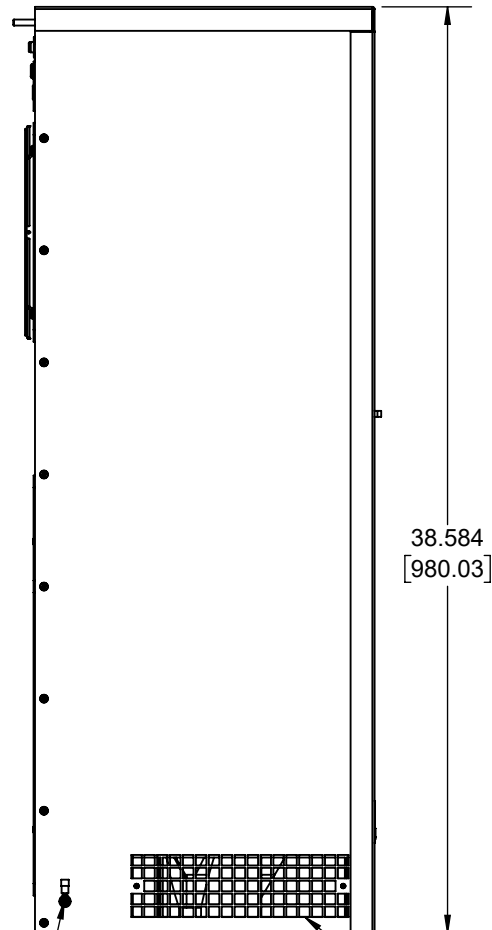
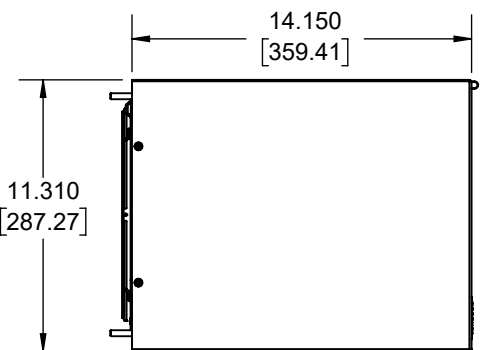
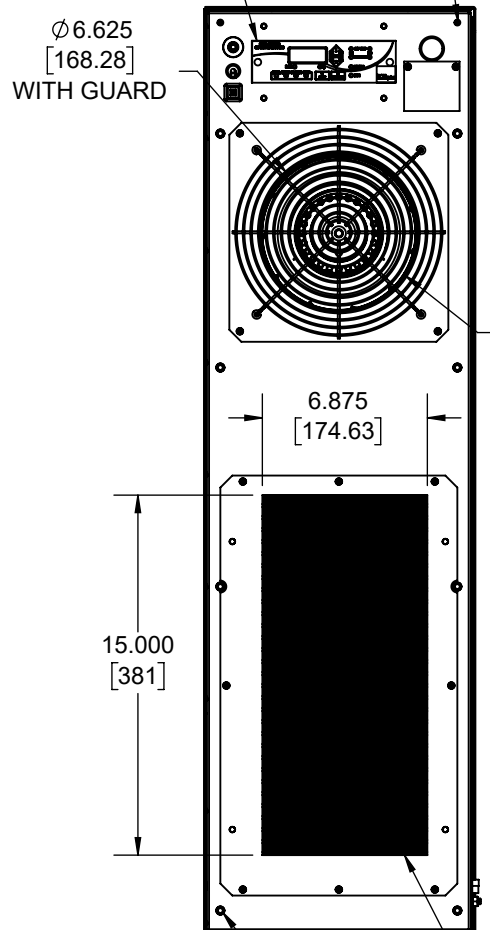
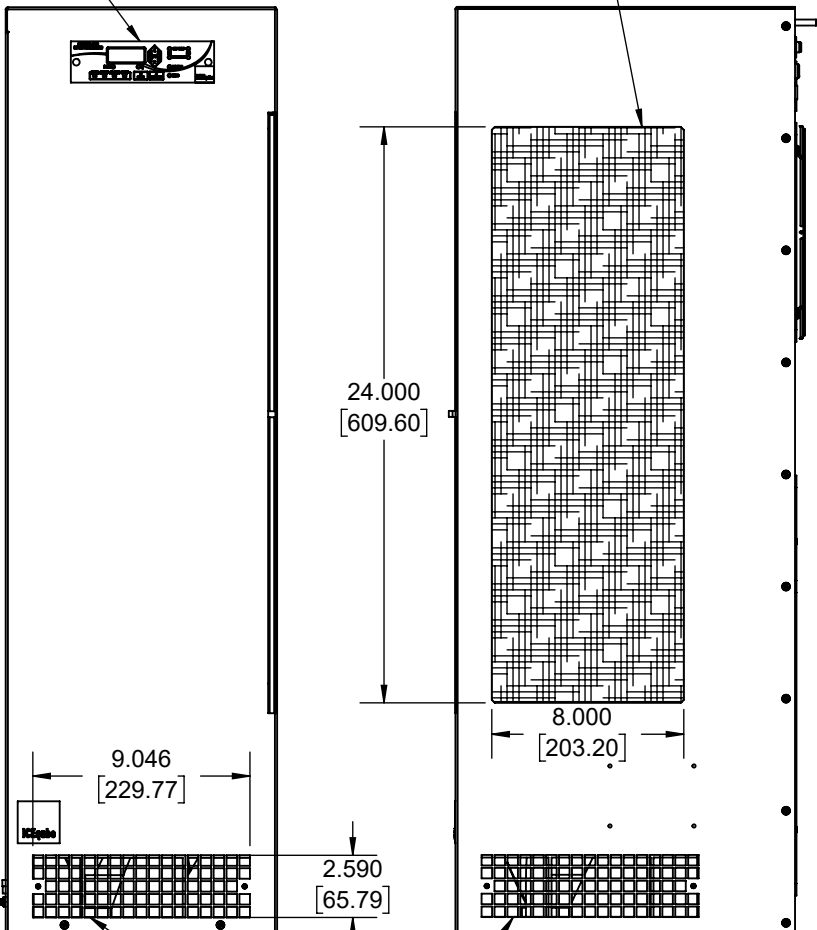

IQ10000EVZ2
 AEx ec IIC T₁ Gc
 Ex ec IIC T₁ Gc
 II 3G Ex ec IIC T₁ Gc
 NOMINAL COOLING CAPACITY:
 10358 BTUH (3036W) @ 60°C-60°C
 10291 BTUH (3016W) @ 35°C-35°C
 MAXIMUM AMPS: 19.80 (2376W) @ 120V/60Hz
 MAXIMUM AMPS: 10.00 (2200W) @ 220V/50Hz
 MAXIMUM AMPS: 10.10 (2323W) @ 230V/60Hz
 MAXIMUM AMPS: 9.26 (2222W) @ 240V/50Hz
 MAXIMUM AMPS: 9.46 (2270W) @ 240V/60Hz
 MAXIMUM AMPS: 5.10 (2040W) @ 400V/50Hz
 MAXIMUM AMPS: 5.09 (2036W) @ 400V/60Hz
 MAXIMUM AMPS: 5.04 (2217W) @ 440V/50Hz
 MAXIMUM AMPS: 5.20 (2289W) @ 440V/60Hz
 MAXIMUM AMPS: 5.06 (2429W) @ 480V/50Hz
 MAXIMUM AMPS: 5.05 (2424W) @ 480V/60Hz
 MAINTAINS IP66 BETWEEN EQUIPMENT AND ENCLOSURE
 OPERATING TEMPERATURE: -40°C - +60°C
 T CODE: W/O CRANKCASE HEATER- T4
 T CODE: W/ CRANKCASE HEATER- T3
 DIMENSIONS: 38.584" (980MM) H x 11.309" (287MM) W x 14.150" (359MM) D
 WEIGHT: 126 LBS (57.2KG) @ 120/220/230/240V
 WEIGHT: 150 LBS (68.0KG) @ 400/440/480V
 REFRIGERANT CHARGE-R407C:
 120V- 39OZ (1106G)
 220/230/240V-400/440/480V- 36OZ (1021G)

**RELATED DRAWING; DO NOT CHANGE WITHOUT
AUTHORIZED PERSON APPROVAL.**

ITEM NUMBER	N/A				
MATERIAL	N/A				
USED ON	IQ10000EVZ2				
EST WT:	lbs				
DRAWN BY	DATE	SCALE			
ART	1/19/2017	1:8			
REV	CHG	DATE	APP	DATE	CN #
D	ADDED AEx AND Ex CERTIFICATION INFORMATION		NAT	4/27/2021	21-0186
C	ADDED CFM, dBA, 240V AND 440V 50/60HZ, AND CLEARANCE INFO		RCC	4/26/2018	JGG 4/26/2018
B	ADDED METRIC VALUES		ART	1/10/2018	JGG 1/10/2018 1336

UNLESS OTHERWISE SPECIFIED TOLERANCES	
.X	±.060
.XX	±.030
.XXX	±.015
FRACTIONAL	±1/16
ANGULAR	±1/2°
SURFACE FINISH	63
DO NOT SCALE DRAWING DIMENSIONS ARE INCHES	

ICE QUBE, INC.

THIS IS A PROPRIETARY DOCUMENT. DO NOT REPRODUCE OR DISCLOSE WITHOUT THE EXPRESS WRITTEN PERMISSION OF ICE QUBE, INC.

DESCRIPTION
IQ10000EVZ2 ZONE 2 ATEX IECEx SPEC DRAWING

DRAWING NUMBER
IQ351312

REV
D

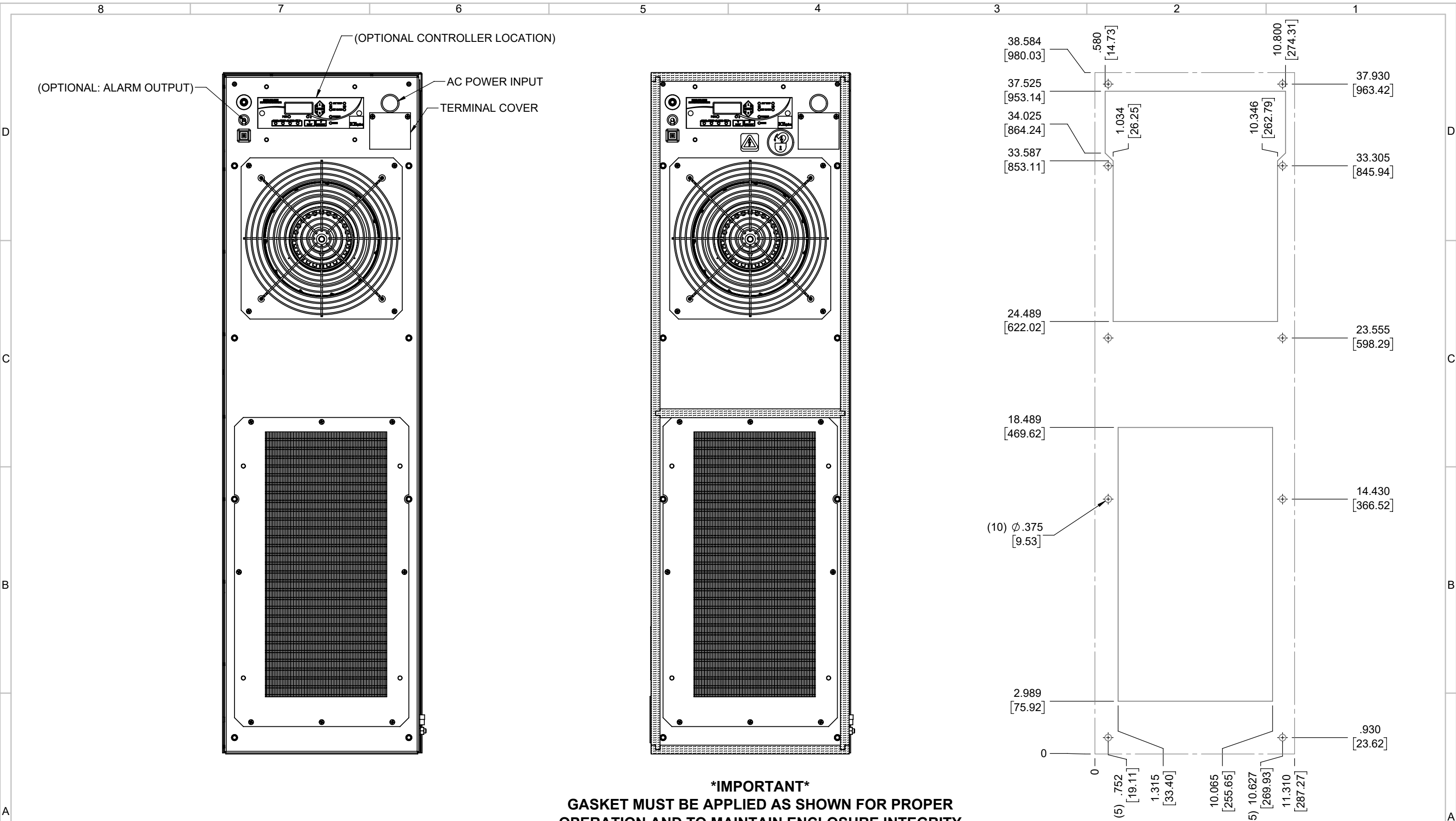

IMPORTANT
GASKET MUST BE APPLIED AS SHOWN FOR PROPER OPERATION AND TO MAINTAIN ENCLOSURE INTEGRITY

EVAP. OUTLET \approx 510 CFM
 COND. OUTLET \approx 800 CFM
 SOUND LEVEL @5FT FROM UNIT @ A HT. OF 3FT = 68 dBA
 SOUND LEVEL @2FT FROM UNIT @ A HT. OF 5FT = 70 dBA
 CONDENSER INLET MIN. CLEARANCE 3.00"

ITEM NUMBER N/A	USED ON IQ10000EVZ2	UNLESS OTHERWISE SPECIFIED TOLERANCES X \pm .060 .XX \pm .030 .XXX \pm .015 FRACTIONAL \pm 1/4 ANGULAR \pm 1/2°	<p>ICE QUBE, INC. <small>THIS IS A PROPRIETARY DOCUMENT. DO NOT REPRODUCE OR DISCLOSE WITHOUT THE EXPRESS WRITTEN PERMISSION OF ICE QUBE, INC.</small></p>
MATERIAL N/A		<p>EST WT: lbs</p> <p>DRAWN BY: ART</p> <p>DATE: 1/19/2017</p> <p>SCALE: 1:5</p> <p>SURFACE FINISH: 63</p> <p>DO NOT SCALE DRAWING DIMENSIONS ARE INCHES</p>	
DESCRIPTION IQ10000EVZ2 ZONE 2 ATEX ICEEx SPEC DRAWING			DRAWING NUMBER IQ351312
			REV D