

CC450F TYPE 12 COMPACT CABINET COOLER AIR-TO-AIR FLUSH-MOUNT MODEL

Model	Weight	Rating @ 20°C ΔT BTU / hr	Amps Current Draw at 115 volts AC	Fan Size	Dimensions-Inches (H x W x D)
CC450F	9 lbs	1,400	0.4	2 x 4"	12-1/2 x 8 x 5-5/16

Efficiency: 21.0 Watts / °C ΔT based on average internal cabinet temperature.

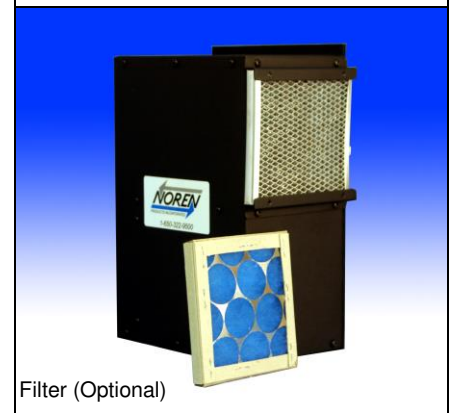
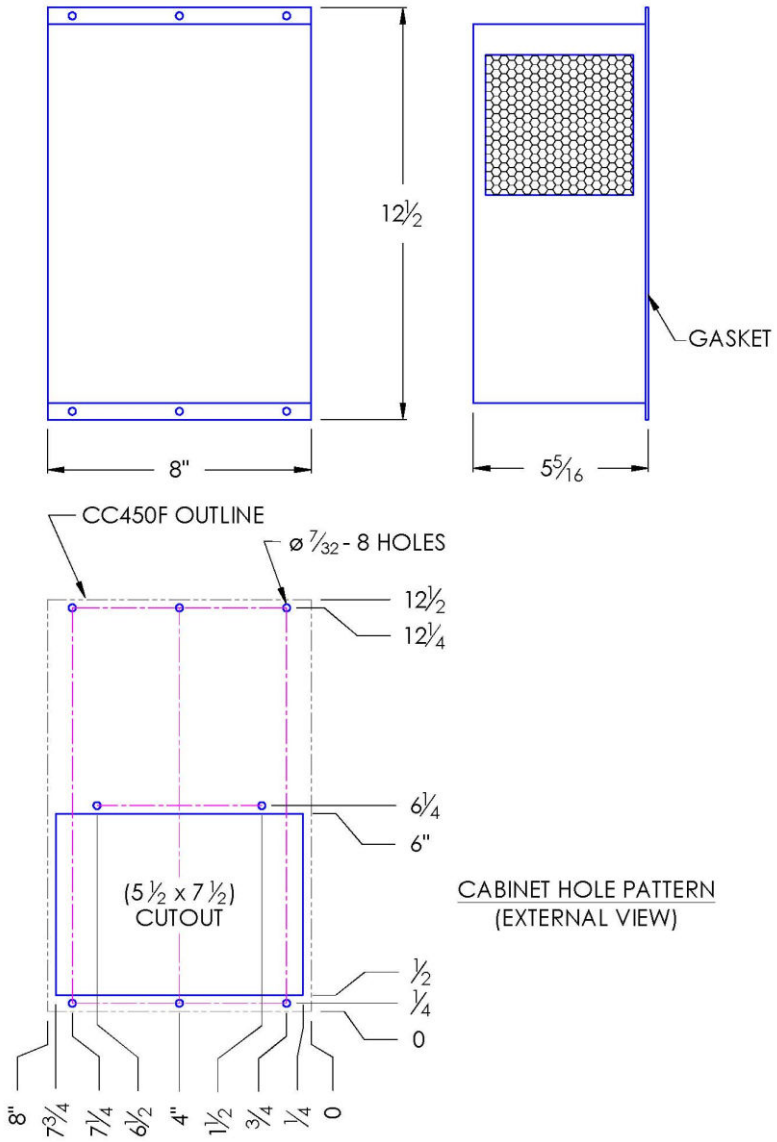

- ### SPECIFICATIONS
- UL Listed for TYPE 12 environments.
 - CC450F Rated cooling: 420 Watts at 20°C ΔT (21.0 W/°C, mounted to an uninsulated 24" X 24" X 16" Cabinet)
 - Designed for surface mounting on outside of cabinet.
 - Housing is aluminum (color is black). Stainless steel is available.
 - Equipped with mounting gasket to maintain air tight seal.
 - Internal 6-ft. power cord with 3-prong plug is standard for AC powered units.
 - Available with VAC (115 & 230) and VDC (12, 24, & 48) fans. DC powered units include junction box, consult website.
 - Unit may be mounted vertically (as shown) or horizontally.
 - Optional: inlet air-filter kit available upon request.
 - 10. For design, quote, and sizing assistance: call (888) 754-6329, (416) 288-1736**





UL File #SA9567 Proudly made in the USA FM 554949

Pelmar Engineering Ltd.
 Tel. (888) 754-6329
 sales@pelmareng.com
 www.pelmareng.com

CC450F TYPE 12

CCS-PBD-8.2.1-883366-C

Subject to change without notice.